

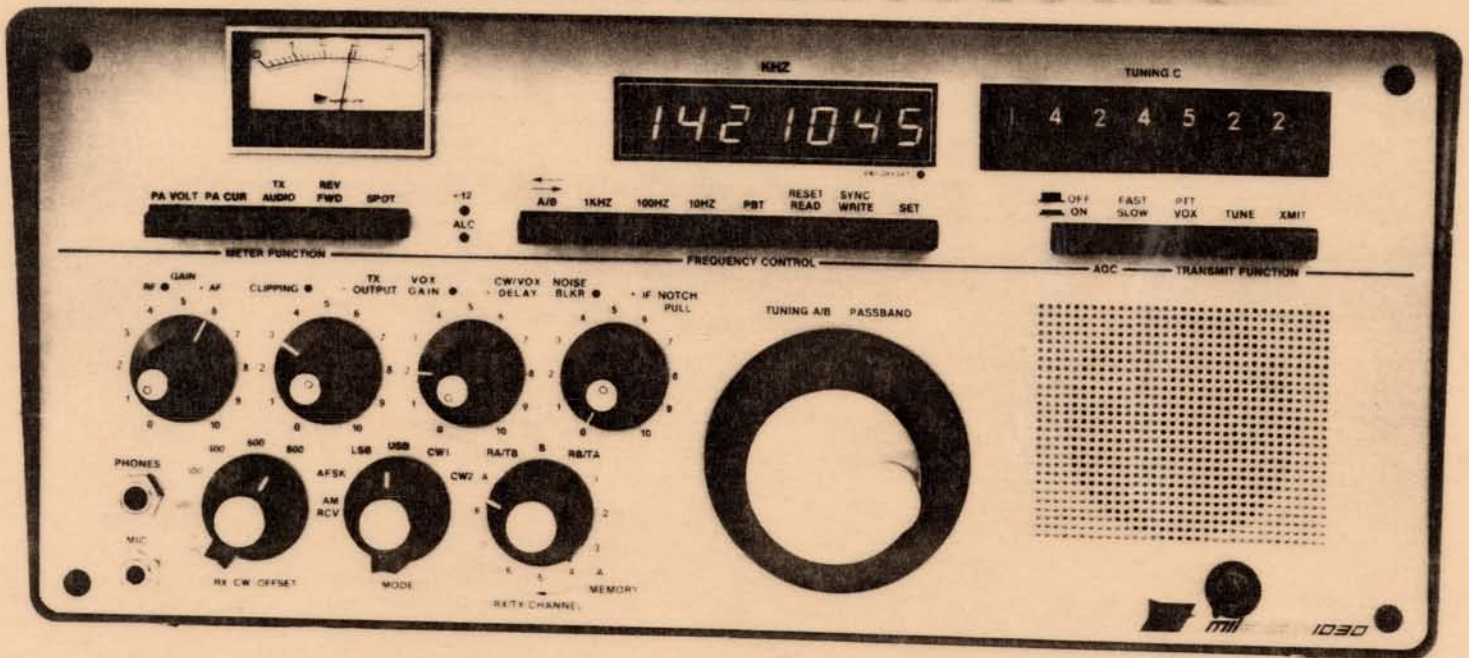

10KHZ-30 MHz HF TRANSCEIVER

COMPUTER CONTROLLED MODULAR SYSTEM



OPERATING AND TECHNICAL MANUAL



7359 E. Softwind Drive, Scottsdale, Arizona 85255

COPYRIGHT 1981 SIGNAL ONE CORPORATION. ALL RIGHTS RESERVED

Table of Contents

A	A1- 10MHz Oven controlled reference oscillator
B	A2 - BFO 450kHz - 460kHz Synthesizer
C	A3 - L.O. Amp. 40MHz Phase lock oscillator
D	A4 - Output loop 40.455MHz - 70.455MHz Synthesizer
E	A5 - Step loop 40MHz - 69MHz Synthesizer
F	A6 - First loop 455KHz - 1.455MHz Synthesizer
G	A7 - Tuning A/B
H	A8 - Memory
I	A9 - Digital Interface
J	A10 - Mother Board
K	A11 - LED Readout
L	A12 - Push Button Assembly
M	A13 - Potentiometer Assembly
N	A14 - RX, CW offset / Mode switch
O	A15 - Receiver / Transmit Assembly
P	A16 -Audio, Main power supply, A19 - Pass transistor, A22 - (-15V) P.S.
Q	A17 - Noise Blanker
R	A18 - Rear Panel I/O Assembly
S	A20 - T/R Relay
T	A21 - SRF-3828 Final Amplifier
U	A23 - Fan Assembly
V	A24 - Synthesizer lockout 40MHz - 70MHz comparitor
W	A25 - TX/RX Low pass filter Assembly - USMC Production (requires new chassis)
X	A26 - Computer Interface Hardware / Software
Y	A10 - Mother Board Run List / Coax Run List
Z	MS- 1030C Components Parts List



TABLE OF CONTENTS

	<u>PAGE</u>
INTRODUCTION	1
UNPACKING	3
OPTIONAL ACCESSORIES AND INSTALLATION	4
OPERATING LOCATION	6
ANTENNA AND GROUNDING	6
POWER TRANSFORMER INSTALLATION	7
MEMORY BATTERY INSTALLATION	8
POWER REQUIREMENTS	8
OPERATION	11
SPECIFICATIONS	24
LIST OF CIRCUIT BOARDS	27
TROUBLESHOOTING	29
MAINTENANCE	33
WARRANTY INFORMATION	34
OPTIONAL RELAY CONTROL	35

IMPORTANT: BEFORE APPLYING POWER IT IS ABSOLUTELY ESSENTIAL TO READ AND FOLLOW ALL INSTALLATION AND OPERATING INSTRUCTIONS IN THIS MANUAL. POSSIBLE SERIOUS DAMAGE TO THE EQUIPMENT MAY RESULT FROM FAILURE TO COMPLY WITH ALL INSTALLATION AND OPERATING INSTRUCTIONS HEREIN AND WILL NOT BE COVERED BY WARRANTY.

Don Roehrs
602-585-4025



DESCRIPTION AND THEORY OF OPERATION

The new MILSPEC 1030C Communication Transceiver introduced by SIGNAL ONE CORPORATION is a fully synthesized, tunable, solid-state transceiver that covers the frequency range from 10 KHz to 30 MHz in 10 Hz steps. The MILSPEC 1030 has many unique features not previously available. Included are frequency preset, receive A/B and transmit B/A, frequency storage with 8 separate memories, remote control and remote programmability. Features that permit the transceiver to be used in computer based communication systems.

This computer interface capability allows the transceiver to store and decipher morse code and teletype transmissions. Also capable of remote control and programming via an interface card and IEEE bus, permitting simultaneous control of any number of separate MILSPEC 1030 transceivers.

Other features of the transceiver include provision for all reception modes SSB, CW, AM, FSK (455 KHz output for FSK demodulation), selectable I.F. bandwidths, electronic passband tuning and excellent immunity to strong signal overload. The three selectable speeds of the optical shaft encoder (180 KHz, 18 KHz or 1.8 KHz per 360 degree of dial revolution) give the feel and smoothness of an analog VFO in quasi-continuous tuning with backlash-free performance while retaining the accuracy and stability of the internal or external frequency standard. No separate MHz or bandswitch control is required - the frequency may be preset with the lever switches, then returned to VFO control. The fast switching synthesizer permits frequency jumps of 30 MHz in less than 10 milliseconds.

All internal frequency controls, including BFO, are derived from a master crystal standard with a maximum instability of 1 Hz/degree Centigrade. For more demanding stability requirements there is provision for an external rubidium or cesium frequency standard.

The fully synthesized BFO provides a ± 5 KHz tuning range. Almost all frequency synthesizer circuitry is based on CMOS circuits. This reduces power consumption in this section to less than 2 watts and enhances reliability because of heat reduction. Spectral purity of the synthesizer is improved because of the great reduction of digital noise. The CMOS memories and standby battery provide storage of frequency data for at least one year in the event of power failures. Upon restoration of power the transceiver will return to the previously tuned frequency.

The receiver section uses a specially developed, high-level double-quad passive mixer with monolithic hot carrier diodes, which is terminated in a low noise amplifier with heavy feed-back for excellent sensitivity without any requirement for an RF amplifier.



Sensitivity on SSB, CW and FSK is typically .25 uV and on AM is 2.6 uV for 10 dB signal to noise ratio. Noise figure is less than 10 dB from 1 to 30 MHz. Third order intercept point is +20 dBm with signals separated by 20 KHz; second order IMD is -80 dB.

The first IF is at 40.455 MHz, second IF is at 455 KHz. To improve input selectivity the 8 pole 40.455 MHz crystal filter has a bandwidth of ± 3.5 KHz with a 1:2 shape factor. This filter was designed specifically for low IMD products. Three built-in 455 KHz IF mechanical filters for 2.1 KHz USB, 2.1 KHz LSB/AFSK and 1.9 KHz CW have been selected for optimum performance. Other optional plug-in mechanical filters available are 5.8 KHz AM, 300 Hz AFSK/LSB (centered on high tone pair), 350 Hz CW and 200 Hz CW with extra steep skirts. The built-in PASSBAND feature (controlled by main tuning knob) is accomplished by electronically shifting the LO and BFO frequencies.

The very effective AGC system is based on a new type AGC processor with separate detectors for precise control of attack and delay times, with a minimum AGC range of 120 dB with threshold at .25uV. There is less than 6 dB audio change with RF inputs from 1 uV to 100 uV. On SSB the AGC attack time is 50 ms; hold and hang time is 1.5 seconds and release time is 100 ms (typical). For AM reception, AGC attack time is 10 ms; release time is 35 ms.

The transmitter portion uses Motorola designed solid-state, broadband power amplifiers (150 or 200 watt output) with excellent IMD performance and as a result transmitter adjustments are not required when changing from one frequency to another, a unique feature Signal One was first to introduce to the amateur market. An RF speech envelope clipper plus cascaded 8 pole filters in SSB, a complex form of speech processing improve intelligibility providing an increase in transmitted strength of substantial proportions.

Seven digit, 10 Hz resolution display with .43 inch character height insures accurate, wide angle interpretation. Three color display is optional. Built-in power supply features heavy duty HyperSil tape wound transformer for exceptional regulation and power with compact size and weight.

Modular construction and plug in circuit boards utilizes a Berg/DuPont mass termination ribbon interconnection system for easy circuit board accessibility. Gold plated Mini-sert transistor sockets and all plug in IC's insure maximum field serviceability. These construction techniques employ the same Berg system that was originally developed for the Tektronix Corporation and has proven reliable for the last decade.

The resulting MILSPEC 1030 High Frequency Communication System contains everything needed for transmitting and receiving in a single unit providing for a more efficient operation. External wiring, normally required when external equipment is used, is kept to an absolute minimum. The result is a highly reliable, serviceable unit with performance exceeding that of any competitive transceiver available today.

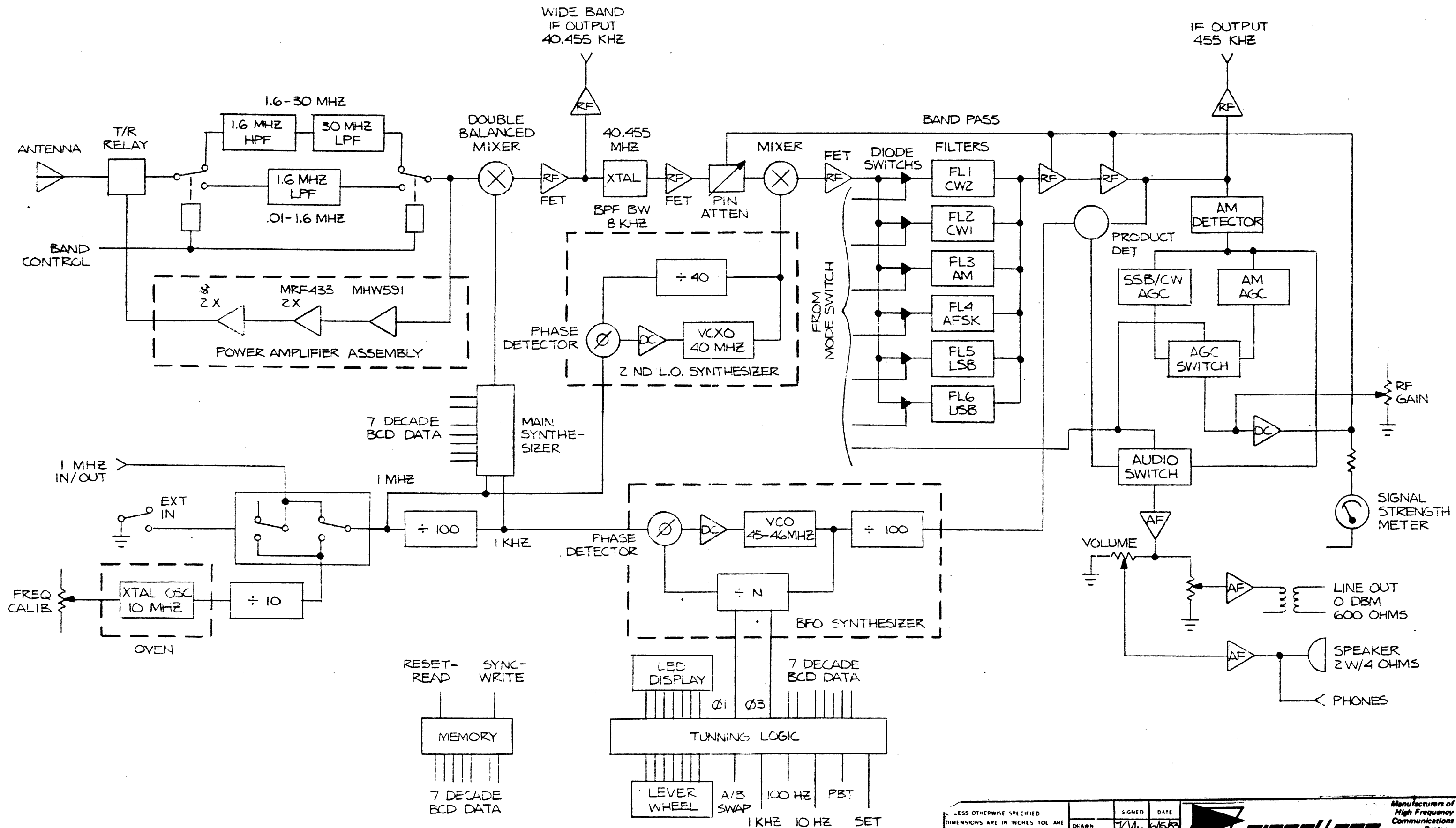

PROPRIETARY DOCUMENT THIS DRAWING AND/OR INFORMATION OR SUBJECT MATTER CONTAINED HEREIN, SHALL NOT BE USED, COPIED OR DISSEMINATED IN ANY MANNER, OR FOR ANY PURPOSE, OTHER THAN AS EXPRESSLY STATED BY SIGNAL ONE CORPORATION COPYRIGHT © 1981 ALL RIGHTS RESERVED.	DRAWN <i>[Signature]</i>	SIGNED <i>[Signature]</i>	DATE 6/15/83	 signal/one Manufacturers of High Frequency Communications Systems	
	CHECKED <i>[Signature]</i>	LE APP'D <i>[Signature]</i>	DATE 3/29/84		
	ME APP'D	GA APP'D	SIZE 1030		SHEET NO. 3
	SCALE NONE	SHEET 1 OF 1	ISSUE A		

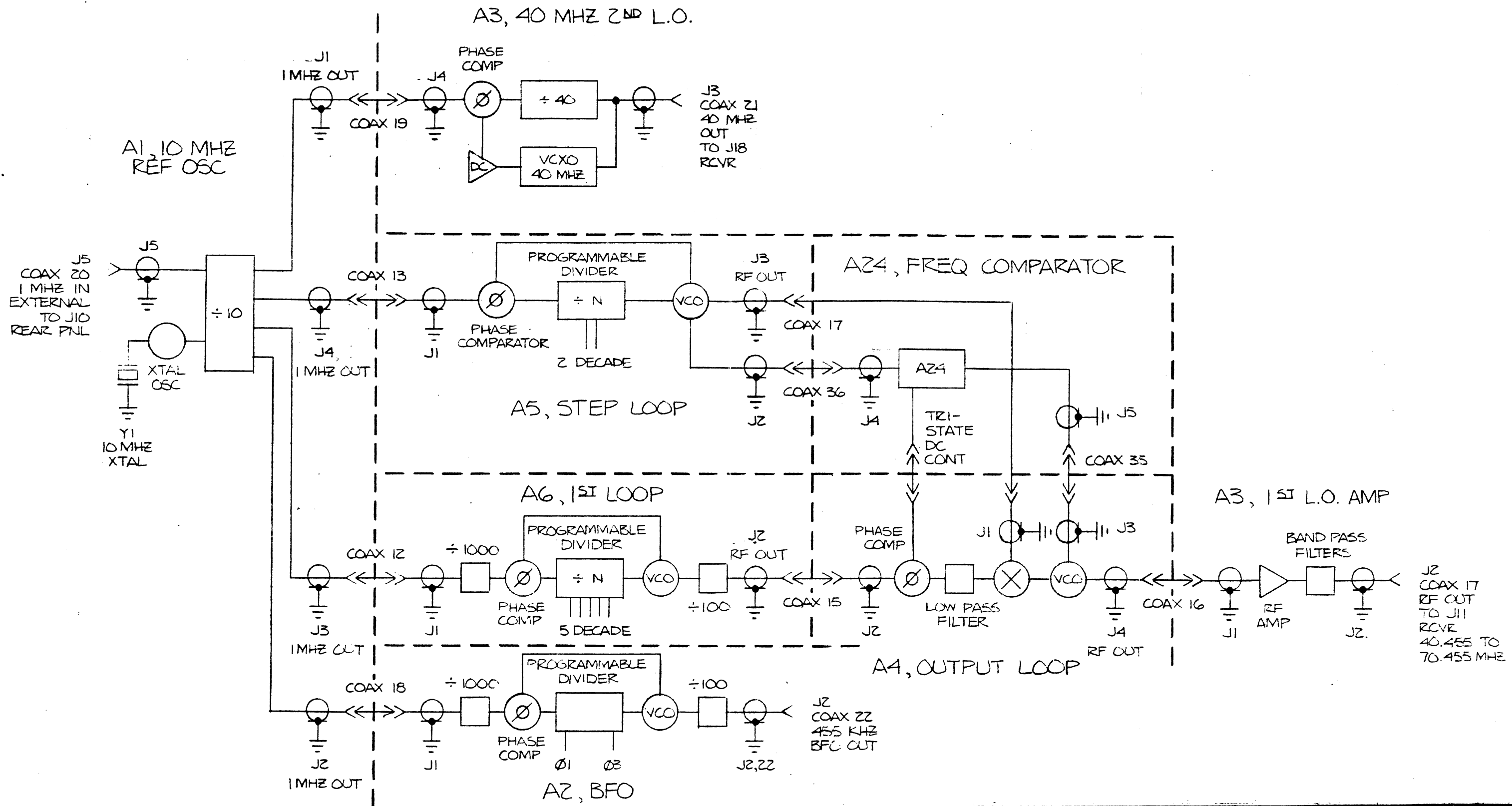

UNLESS OTHERWISE SPECIFIED DIMENSIONS ARE IN INCHES TOL ARE DECIMALS .XX ± .01 .XXX ± .005 ANGLES 2° SURFACE FINISH #4 CONCENTRICITY .004 TIR	SIGNED	DATE	 signal/one <small>Manufacturers of High Frequency Communications Systems</small>									
	DRAWN	DATE										
<small>PROPRIETARY DOCUMENT THIS DRAWING AND/OR INFORMATION OR SUBJECT MATTER CONTAINED HEREIN, SHALL NOT BE USED, COPIED OR DISSEMINATED IN ANY MANNER, FOR ANY PURPOSES, OTHER THAN AS EXPRESSLY STATED BY SIGNAL ONE CORPORATION. COPYRIGHT © 1981. ALL RIGHTS RESERVED.</small>	CHECKED	DATE	BLOCK DIAGRAM, SYNTHESIZER									
	DATE	DATE										
	SCALE	SHEET	OF	<table border="1"> <tr> <td>SIZE</td> <td>CUT LIST NO.</td> <td>REV. NO.</td> <td>ISSUE</td> </tr> <tr> <td>1030</td> <td>1</td> <td></td> <td>A</td> </tr> </table>	SIZE	CUT LIST NO.	REV. NO.	ISSUE	1030	1		A
	SIZE	CUT LIST NO.	REV. NO.	ISSUE								
1030	1		A									
SCALE NONE			SHEET 1 OF 1									

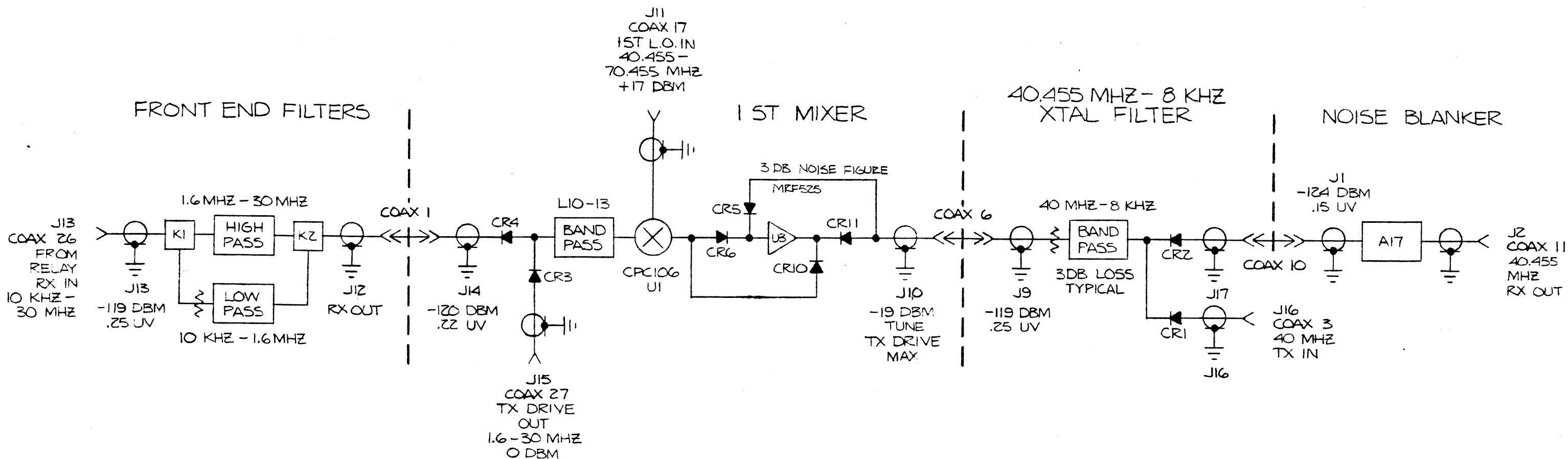

UNLESS OTHERWISE SPECIFIED DIMENSIONS ARE IN INCHES TOL ARE DECIMALS .XX ± .01 XXX ± .005 ANGLES 2° SURFACE FINISH ✓ CONCENTRICITY .004 TIR		SIGNED	DATE	 signal/one <small>Manufacturers of High Frequency Communications Systems</small>	
PROPRIETARY DOCUMENT THIS DRAWING AND/OR INFORMATION OR SUBJECT MATTER CONTAINED HEREIN, SHALL NOT BE USED, COPIED OR DISSEMINATED IN ANY MANNER, OR FOR ANY PURPOSE, OTHER THAN AS EXPRESSLY STATED BY SIGNAL ONE CORPORATION. COPYRIGHT © 1981 ALL RIGHTS RESERVED.		DRAWN T.M.	6/15/83		
		CHECKED D.W.	3/29/84		
ME APP'D _____ QA APP'D _____				TITLE BLOCK DIAGRAM, RECEIVER	
		SIZE	LOGIC IDENT NO	DWG NO	REV
		NONE	1030	Z	A
		SCALE	SHEET		
		NONE	1 OF 2		

2ND MIXER

J18, COAX Z1
40 MHz, 2ND L.O.
+0 DBM, 1.5 V RMS

455 KHZ IF

DETECTOR/NOTCH FILTER

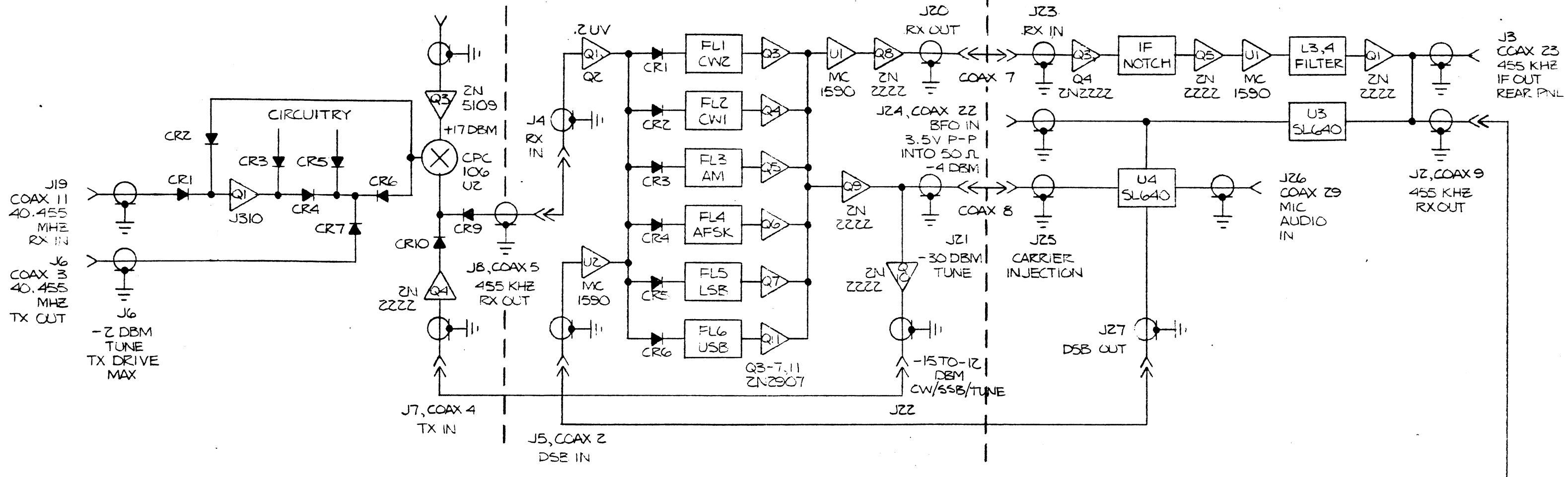

AGC

PART OF J1

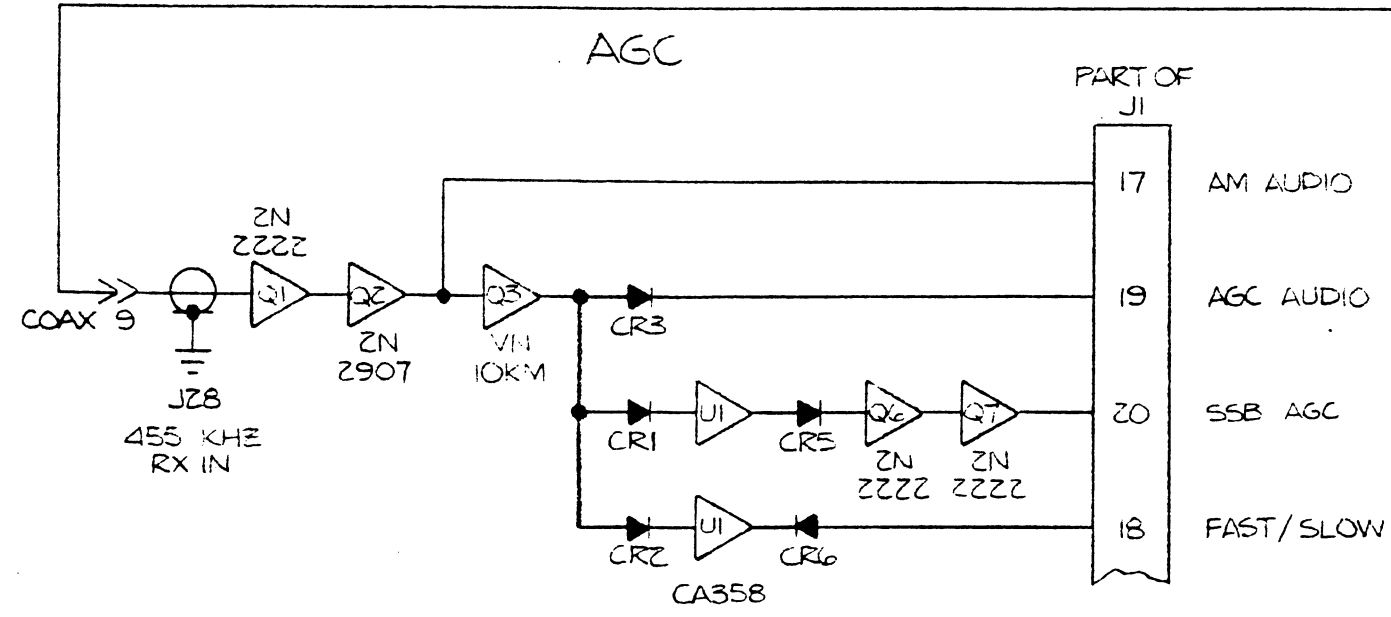

UNLESS OTHERWISE SPECIFIED DIMENSIONS ARE IN INCHES TOL ARE DECIMALS XX ± 01 XXX ± 005 ANGLES 2 ° SURFACE FINISH #2/ CONCENTRICITY 0.04 TIR		SIGNED	DATE	<p>signal/one Manufacturers of High Frequency Communications Systems</p>
DRAWN	7/1/83	4/5/83		
CHECKED	1/9/83	3/29/83		
EE APP'D				
PROPRIETARY DOCUMENT THIS DRAWING AND/OR INFORMATION OR SUBJECT MATTER CONTAINED HEREIN, SHALL NOT BE USED, COPIED OR DISSEMINATED IN ANY MANNER, OR FOR ANY PURPOSE, OTHER THAN AS EXPRESSLY STATED BY SIGNAL ONE CORPORATION. COPYRIGHT © 1981 ALL RIGHTS RESERVED.				BLOCK DIAGRAM, RECEIVER
MT APP'D				SIZE: 1030 LOG: SENT NO: 2 DRAW NO: A
QA APP'D				SCALE: NONE SHEET: 2 OF 2



UNPACKING

Because of UPS weight limitations and MILSPEC 1030 transceiver is shipped in 2 separate cartons.

One contains the transceiver and the other its power transformer. Carefully unpack both cartons and check for the following contents:

TRANSCEIVER CARTON:

- 1 - MILSPEC 1030 transceiver
- 1 - AC power cord
- 1 - Microphone jack
- 1 - MILSPEC 1030 operation manual

TRANSFORMER CARTON:

- 1 - MILSPEC 1030 power transformer
- 4 - 10-32 hold down screws, flat and lock washers

Should there be any shipping damage, notify carrier immediately to file claim for any damages.

Save all shipping cartons and packing material should it become necessary to ship the unit. For factory service the transceiver should be shipped without transformer.



OPTIONAL ACCESSORIES AND INSTALLATION

HIGH POWER OUTPUT OPTION includes heavy duty vacuum relay board and twin rear blower package. High power relay board cannot be owner installed. Blowers are recommended for 150 watt output when in RTTY or SSTV modes.

TWIN BLOWER INSTALLATION

- 1 - Position blower assembly near rear of transceiver so AC connector is toward bottom.
- 2 - Insert 2 4-40 X 1/4 inch screws with washers through thermostat and install to flat area above pass transistor between heatsink fins.
- 3 - Plug AC cord from fan bracket into AC connector of transceiver.
- 4 - Remove 2 outer screws from both the pass transistor heatsink and driver/final heatsink.
- 5 - Hold fan bracket against heatsink flanges and re-install 4 screws with washers. Be careful fo avoid pinching AC cord between fins and bracket.

DC POWER CORD - A 6 foot long, #8 AWG power cable with AMP connector to mate with rear panel is available for operation from a 12.6 to 15 volt (maximum) DC source capable of at least 35 amperes.

CW2 FILTERS - For narrow CW reception in the CW2 mode switch position a 375 Hz or 200 Hz filters are available. To install, remove top and bottom cabinet halves. Remove RECEIVER (A15) cover. Plug filter into FL1 position. Replace covers.

AFSK/LSB FILTER - For RTTY operation in the AFSK mode switch position a 300 Hz filter is available centered on the HIGH TONE pair frequency at 2210 Hz. Plug filter into FL4 position. Installation is similar to the CW2 filter except the filter must be positioned so that the Pin marked with the ground symbol (\perp) is mated with the grounded socket. (Located nearest to Q6, C38).

AM FILTER - For AM reception in the AM RCV mode switch position, a 5.8 KHz filter is available. Plug filter into FL3 position. Installation is the same as CW2 filter.

OPTIONAL CW FILTERS - Special CW1, CW2 filters are available. Contact Factory



COMPUTER CONTROL OR REMOTE OPERATION - Two (2) rear panel DB-25 connectors are provided. An RS-232 computer interface MSA-26CI and accessory connector furnish the necessary functions for computer and remote operation.

Complete INPUT/OUTPUT information for using these connectors and functions is included in SECTION A26, COMPUTER INTERFACE.



OPERATING LOCATION

Operation of transceiver should be away from heating vents. Top and sides must remain unobstructed to allow for proper air flow through and around unit. For high duty cycle operation or in closed quarters the blower assembly must be used.

ANTENNA

The antenna is one of the most important factors in the performance of any radio system. Because of the wide variation from installation to installation, it is beyond the scope of this manual to cover them. Various reference sources on antennas will cover most installation requirements.

The MILSPEC 1030 is designed to operate into a 50 ohm non-reactive load. The output is automatically reduced by approximately 10% with a 2:1 VSWR. It is reduced proportionately more with higher VSWR's.

Table 1 can be used to determine approximate actual forward and reflected power as indicated on the 0 to 5 relative scale of the meter.

GROUNDING

The MILSPEC 1030 and all units used with it should have ground interconnections using heavy #12 AWG wire or larger or ground strap, 1/4 inch or larger between ground lugs of units.

Connect the ground lug on rear panel of transceiver to good earth ground or water pipe ground. If using water pipe ground check to be sure no plastic or other insulating material sections will interrupt connection to ground. Use heavy wire or strap and metal pipe clamps to jumper around any such sections

POWER TRANSFORMER INSTALLATION

1. Remove 6 side and 3 rear screws holding top cover to transceiver.
2. Place four 10-32 flat head screws into transformer hold down plate.
3. Carefully lower transformer into unit as in Figure 1.
4. Tighten four hold down screws.
5. Connect primary and secondary connectors as in Figure 1.
6. Replace top cabinet half.

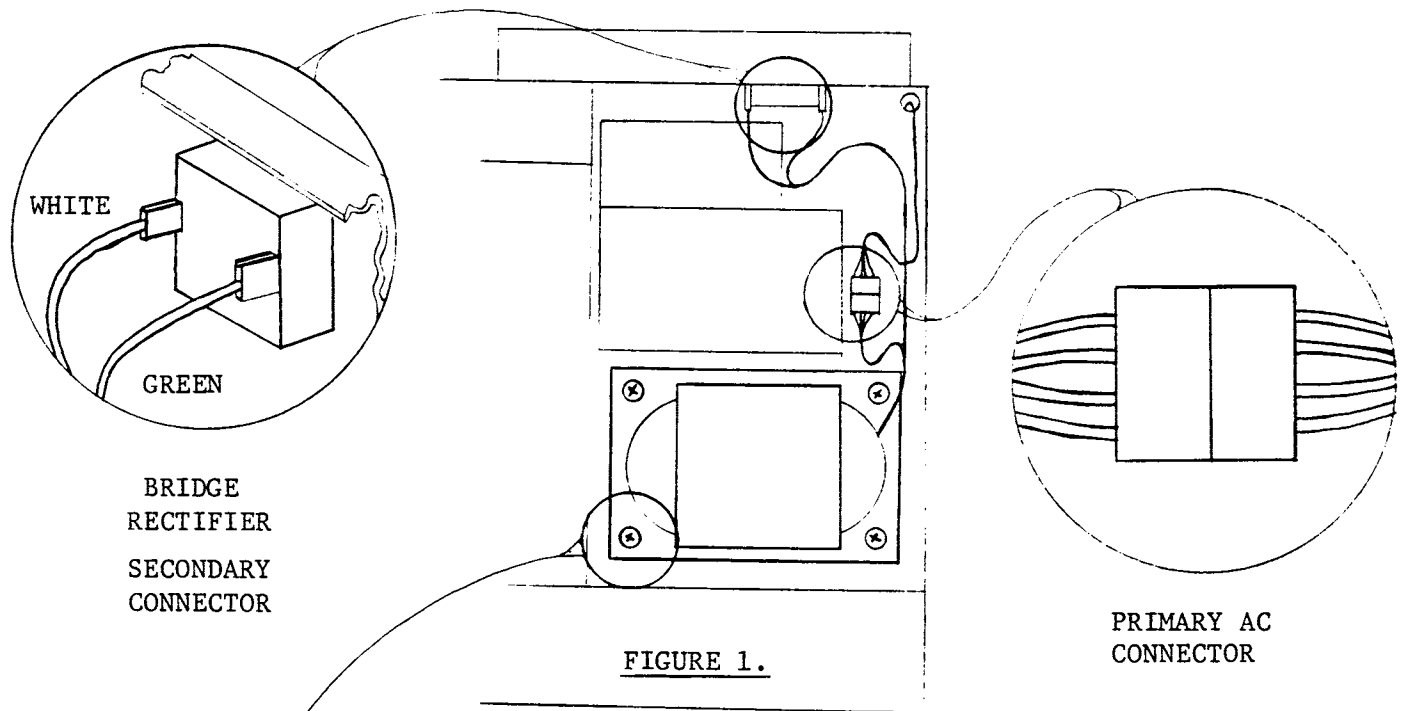
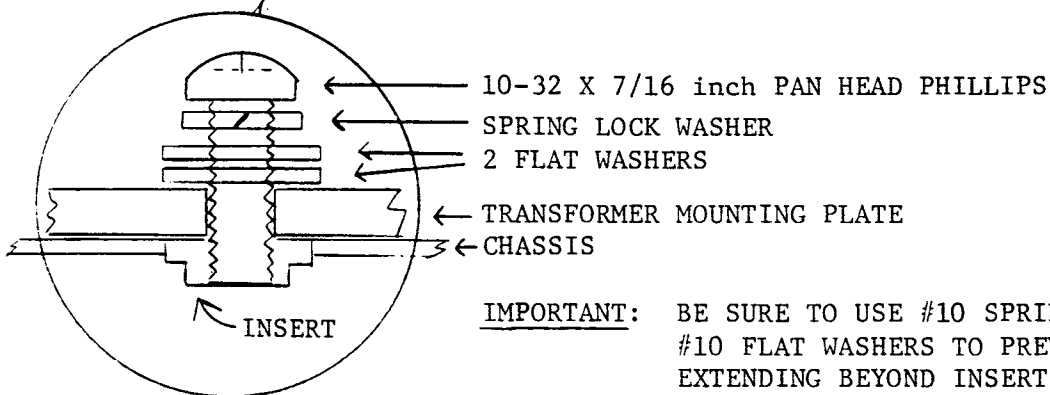

FIGURE 1.



IMPORTANT: BE SURE TO USE #10 SPRING LOCK AND BOTH #10 FLAT WASHERS TO PREVENT SCREW FROM EXTENDING BEYOND INSERT IN CHASSIS.



MEMORY BATTERY INSTALLATION

1. Remove 6 side and 3 rear screws holding top cover to transceiver.
2. Remove 6 bottom and 2 rear screws holding bottom cover to transceiver.
3. Install standard 9 volt transistor battery in holder located on left-front side toward bottom of MOTHER BOARD (A10).
4. Replace top and bottom cabinet halves.

NOTE: When transceiver is dropped shipped to a customer, battery is factory installed.

POWER REQUIREMENTS

The MILSPEC 1030 may be operated on 120 or 240 volts AC, $\pm 5\%$, 50 to 60 Hz at approximately 10 or 5 amps respectively. Primary voltage is selected with a pull out circuit card in the rear panel AC connector.

WARNING: DO NOT ATTEMPT TO CHANGE CIRCUIT CARD OF FUSE IN REAR PANEL AC CONNECTOR WHILE PRIMARY POWER IS APPLIED! ELECTRICAL SHOCK WILL OCCUR! DISCONNECT PRIMARY POWER CABLE FROM UNIT OR POWER SOURCE FIRST!!!

With optional DC cord, the transceiver may be operated from a 12.6 to 15 volts DC (maximum) source capable of supplying 30 amps.

IMPORTANT: MAKE SURE THE POLARITY IS CORRECT AND NOT OVER 15 VOLTS DC MAXIMUM WHEN CONNECTING TO DC SOURCE. REVERSING POLARITY OR APPLYING VOLTAGES OVER 15 VOLTS WILL CAUSE DAMAGE AND VOID WARRANTY.

MICROPHONE PLUG CONNECTION (PJ-068)

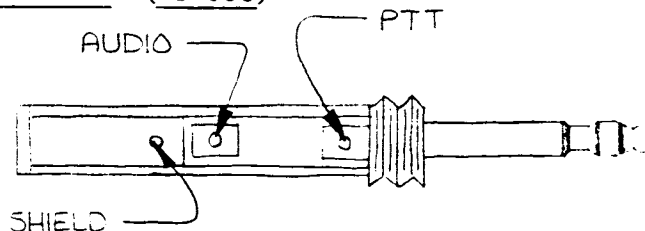
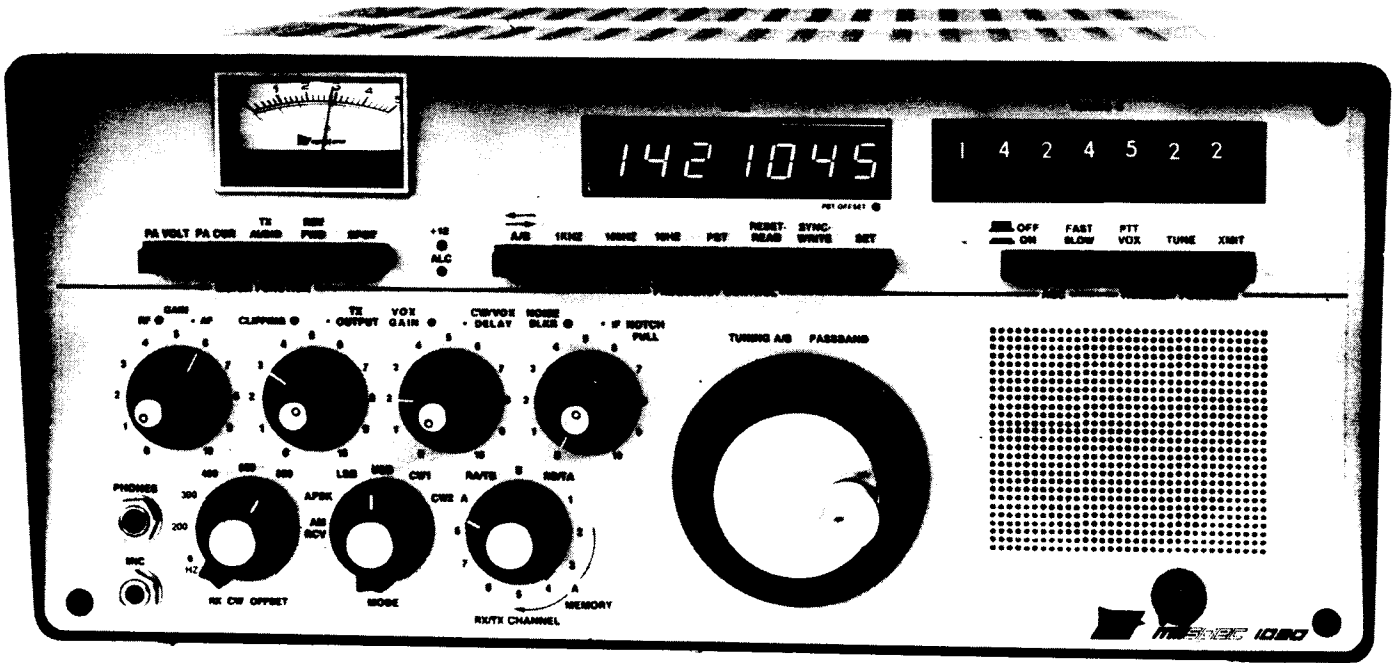

FIGURE 2.



FRONT PANEL

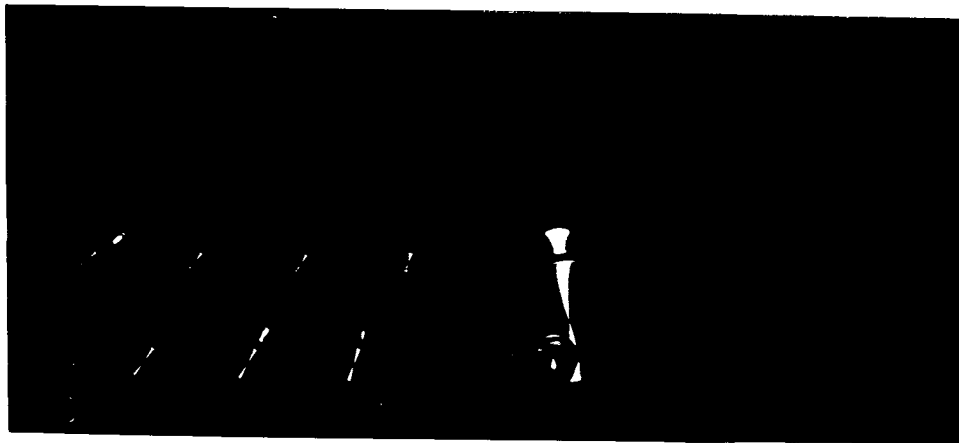
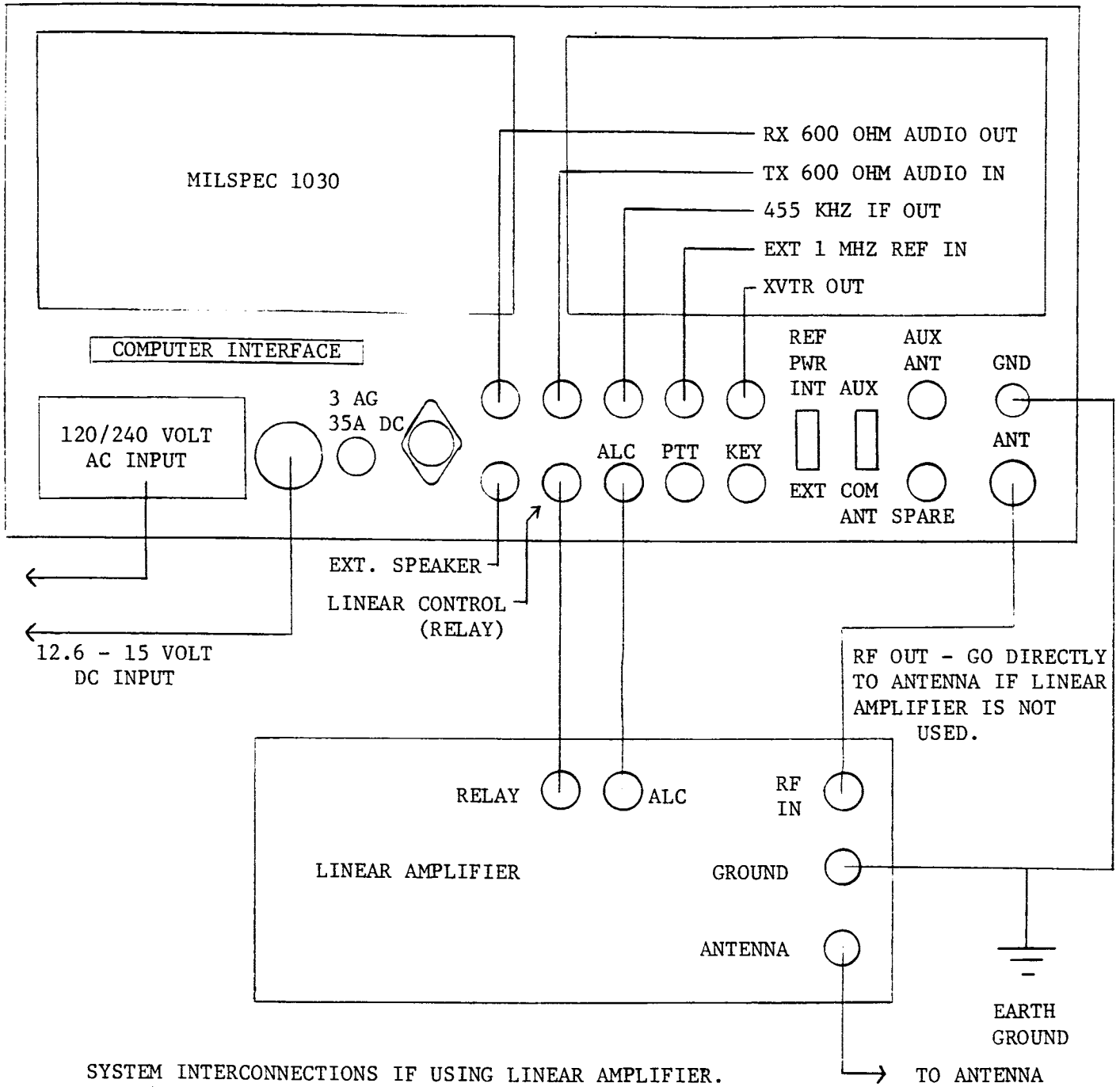

FIGURE 3.





OPERATION

Refer to Table 1 and Figure 2 for explanation of front panel control functions. Refer to Table 2 and Figure 3 for rear panel functions.

TABLE 1.

<u>ITEM</u>	<u>FUNCTION</u>
METER	Bottom scale indicates receive signal strength in "S" units. 50uV (-73dBm) at the antenna jack equals "S9". 1uV (-107dBm) equals "S1" and 50mV (-13dBm) equals "S60". 0 to 5 scale indicates signal selected by METER FUNCTION push buttons.
KHZ	Displays transmit, receive or memory frequencies in Kilohertz with 10 Hertz resolution.
PBT OFFSET	When on, indicates passband tuning mode. Display shows receive frequency plus offset frequency added.
TUNING C	Lever switches used for presetting frequencies for memory or making large frequency changes, as in jumping from band to band, crossband operation or returning to initial frequency selected by TUNING C, to avoid unnecessary manual tuning.
PA VOLT	When pressed, indicates voltage to final amplifier in transmit and receive. Normal reading of 13.8VDC is indicated by approximately 3.2 on the 0 to 5 scale.
PA CUR	When pressed, indicates current to final amplifier in transmit and receive. Current reading is obtained by multiplying reading on 0 to 5 scale by 10; example 2.0 = 20 amps.
TX AUDIO	When pressed, indicates relative microphone or phone patch audio in transmit. Nominal reading is 2 - 3 on the 0 to 5 relative scale.



<u>ITEM</u>	<u>FUNCTION</u>
FWD/REV	When in, indicates forward RF output power to load in transmit. When out, indicates relative reverse RF power from load in transmit. Slight pressure on PA VOLT, PA CUR or TX AUDIO will snap FWR/REV button out. With 150 or 200 watts output into a 50 ohm matched load, normal forward readings are 4.2 or 4.8 respectively on 0 to 5 scale. See table 1. Indicates "S" units in receive.
SPOT	Momentary push button, gives spot tone in speaker equal to RX CW OFFSET selected 0, 200, 300, 400, 600 or 800 Hz to provide selected audio tones to aid in placing your transmit frequency in the clear in relation to the "cw pile" in DX operation.
+12V	Red LED, when on indicates low +12V DC to final amplifier or excessive PA collector current.
ALC	Amber LED, when on indicates RF output peaks within 30 to 40 watts of 150 or 200 watt output in transmit.
AB	A/B inverting momentary push button, when pressed allows receiving on the transmit frequency when in RA/TB or RB/TA split mode. Reverses the normally entered RX/TX frequencies. Momentarily eliminates any PBT offset.
1 KHZ	When pressed, frequency changes in 1 KHz increments as TUNING A/B knob is rotated.
100 HZ	When pressed, frequency changes in 100 HZ increments as TUNING A/B knob is rotated.
10 HZ	When pressed, frequency changes in 10 Hz increments as TUNING A/B knob is rotated.
DIAL LOCK (not labled)	With the 1 KHZ, 100 HZ and 10 HZ push buttons out, the frequency is locked where last set and will not change as the TUNING A/B knob is rotated. Slight pressure on one of the buttons that is out will snap the remaining depressed one out. For remote operation dial lock must be enabled. Tuning rate only operative in 10 Hz steps.



<u>ITEM</u>	<u>FUNCTION</u>
PBT	Passband Tuning; momentary push button activates PBT offset. Hold push button in while rotating TUNING A/B knob for desired passband shift. Normal tuning rate is restored when PBT push button is released while maintaining desired PBT offset. To rezero PBT, push RESET. NOTE: Depressing AB SWAP button momentarily eliminates PBT offset in split or transceive mode.
RESET- READ	RESET function; momentary push button rezeros any passband offset in receiver and display. READ function; if in one of the 1 through 8 memory positions, displays and enters frequency stored into A VFO U/D counter.
RIT SYNC- WRITE	SYNC function; momentary push button synchronizes B VFO to A VFO if in the A VFO or RA/TB position and synchronizes A VFO to B VFO if in B VFO or RB/TA position. WRITE function; if in one of the memory positions, enters displayed frequency into that position.
SET	Momentary pushbutton, when pressed displays and enters frequency from TUNING C lever switches into A or B U/D counters selected with RX/TX CHANNEL switch.
OFF ON	Receive automatic gain control, AGC, on when button is in, off when out. Press button to release.
FAST SLOW	Fast AGC decay when out, slow when in. Press to release.
PTT VOX	Voice operated transmit, VOX, when in; push to talk, PTT, when out. Button snaps out with slight pressure on TUNE or TRANSMIT buttons. For full break-in (QSK) CW, set for PTT. For semi break-in, set for VOX.
TUNE	Switches transceiver to transmit mode with RF carrier output in AFSK, LSB or USB. No output in AM, CW1 or CW2. Level controlled with TX DRIVE CONTROL
TRANSMIT	Switches transceiver to transmit mode, like a PTT lock switch. Carrier output in CW1 or CW2. No Output in AFSK, LSB or USB until audio input is applied.



<u>ITEM</u>	<u>FUNCTION</u>
AF GAIN	Controls receive audio volume level to speaker or headphones.
RF GAIN	Manually controls RF gain of receiver 40 MHz 1st IF and 455 KHz 2nd IF sections.
TX OUTPUT	Controls level of transmitted RF output. Power output adjustable down to less than 1 watt.
CLIPPING	Controls Rf clipping level of transmit SSB signal.
CW/VOX DELAY	Controls delay going from transmit to receive in VOX mode.
VOX GAIN	Controls threshold level of MIC or phone patch audio at which transmit occurs in VOX mode.
(Anti-vox internal)	Anti-vox preset at factory. Adjustable with R60 on AUDIO/POWER SUPPLY (A16) board.
IF NOTCH	Pull center knob out to enable. Controls frequency of variable IF notch for attenuation of unwanted carriers in passband of receiver.
NOISE BLANKER	Controls threshold of noise blanker.
RX CW OFFSET	Selects 6 different receive frequency offsets for CW operators who prefer lower frequency notes. Functions only in CW mode.
MODE	Selects AM, AFSK(2210 Hz center frequency), LSB, USB, CW1 or CW2 in receive. AFSK, LSB, USB or CW in transmit.
RX/TX CHANNEL	Controls operation of A and B VFO's and A memory channels 1 through 8. Pressing READ in one of the memory positions transfers frequency into A VFO.
TUNING A/B PASSBAND	Optical encoder main frequency tuning of A and B VFO's. Also controls passband when PASSBAND button is pressed.



<u>ITEM</u>	<u>FUNCTION</u>
PHONES	8 ohm headphone jack. Disconnects internal speaker. Disconnects external speaker if one is connected. Switchcraft PJ-055.
MIC	High impedance microphone input jack. Switchcraft PJ-068 TIP = PTT Line, RING = Mic audio, BARREL = GND
SPEAKER	Internal 4 ohm speaker. 2 watts.
TOGGLE SWITCH	Primary AC/DC, ON/OFF switch. <u>OFF TO RIGHT.</u>

TABLE 2.

<u>ITEM</u>	<u>FUNCTION</u>
AC JACK	Primary AC power connector, 120/240 voltage selector and 10A/5A fuse holder. Belden 17250.
DC JACK	12.6 to 15V DC power connector. AMP 206037-2
DC FUSE HOLDER	35 AMP 3AGC DC fuse in line with positive 12.6 to 15V DC power connector line.
RX 600 OHM AUDIO OUT	600 ohm audio out, 0 dBm \pm 3 dB, level internally adjusted with R63 on A16 audio/power supply board. Independent of front panel AF/RF gain controls. Switchcraft 3507 phono.
TX 600 OHM AUDIO IN	Auxillary transmit audio input for patch and AFSK TX input. Switchcraft 3507 phono.
455 KHZ IF OUT	Monitor jack for 455 KHz 2nd IF signal, 50mV into 50 ohms. Switchcraft 3507 phono.
EXT 1 MHZ REF IN	Input for external 1 MHz reference oscillator signal, 1V EMF; Rs=1K ohm. REF OSC PWR switch must be at EXT. Switchcraft 3507 phono.



<u>ITEM</u>	<u>FUNCTION</u>
XVTR OUT	1.6 through 30 MHz low level, -23 to 0 dBm RF transmit signal adjustable with TX OUTPUT control. Switchcraft 3507 phono.
EXTERNAL SPEAKER	4 to 8 ohm external speaker connection. Disconnects internal speaker. Switchcraft PJ-055
LINEAR CONTROL	Linear amplifier relay control output, normally open. Approximately 22 ohms to ground in transmit. Switchcraft 3507 phono.
ALC	ALC output to linear amplifier, negative going with full ALC at -6 volts. Switchcraft 3507.
PTT	Parallels front panel mic PTT line and rear panel KEY jack. Ground for transmit. Carrier output in CW mode. Switchcraft 3507 phono.
KEY	Hand key or keyer input. Parallels front mic PTT and PTT jack. Ground for transmit. Carrier output in CW mode. Switchcraft PJ-055. (+) Key Line.
RCVR AUX ANT	Input for separate "receive only" antenna. Switchcraft 3507 phono.
SPARE	Switchcraft 3507 phono.
ANTENNA	50 ohm antenna jack, unbalanced. Amphenol PL-259 type.
GROUND	Binding post for connection to earth ground and other station equipment.
REF OSC PWR INT-EXT	Disconnects power to internal 1 MHz reference oscillator when using external reference signal. Normally left at INT position.
AUX-COM ANT	Switches in separate "receive only" antenna.



FREQUENCY SELECTION

The MILSPEC 1030 uses a standard 9 volt transistor battery to store the last entered frequency data in A, B VFO's and 1 through 8 memory channels.

TUNING A/B, MAIN TUNING

Turning the main tuning knob in receive causes the frequency and display to change in selectable 1 KHz, 100 Hz or 10 Hz steps. When one of the 3 tuning rate buttons is pressed, that and all higher digits will change as the knob is rotated. For example, if the 1 KHz button is pressed the 100 Hz and 10 Hz digits will remain where last set while the 1 KHz and higher digits update as the knob is rotated.

With all 3 tuning rate buttons out the frequency is locked against accidental rotation of TUNING A/B knob. Slight pressure on one of the two buttons that is NOT in will snap the depressed button out. In transmit, the frequency is NOT changed when the tuning knob is rotated even if unlocked.

Frequency LAST entered in A or B VFO's is retained when RX/TX CHANNEL is switched out of that position.

TUNING C, FREQUENCY PRESET

The lever switches are used for frequency presetting. To preset, select desired frequency, press SET to enter and display new frequency. This is a very useful feature as band to band or within band changes are accomplished by changing only one or two digits rather than having to enter the entire frequency as with some keyboards. In addition the last TUNING C frequency is retained and displayed providing an additional memory.

Select A, RA/TB, B or RB/TA position, preset frequency desired. Press SET to enter and display frequency into selected VFO.

To preset transmit frequency in split mode, first select new TUNING C frequency. Press inverting AB button, then press SET to enter and display new transmit frequency. In both cases tuning may continue from the new frequency with TUNING A/B knob.



TRANSCEIVE OPERATION

For transmitting and receiving on the same frequency, select the A or B VFO. Recalling a frequency from one of the memory channels will automatically enter new frequency into A VFO. If tuning while in one of the memory channels, that memory and A VFO is automatically updated to the new displayed frequency by auto-write function.

SPLIT FREQUENCY OPERATION

Load frequency into A VFO. Switch RX/TX CHANNEL to B VFO and load second frequency. With switch in RA/TB unit receives in A and transmits in B. With switch in RB/TA unit receives in B and transmits in A.

Any two frequencies may be entered even within different bands. When operating full break-in CW (QSK) the frequency split is limited to ± 10 KHz within segments of xx000.00 to xx199.99, xx200.00 to xx499.99 or xx500.00 to xx999.99 KHz within any 1 MHz segment.

Pressing the inverting AB button when in split mode, the transmit frequency may be received and tuned with TUNING A/B.

RIT OPERATION

Select RA/TB or RB/TA. When a station is tuned in and upon initiating a contact, press SYNC. RIT operation begins simply by tuning main tuning knob. Transmit frequency stored in TB or TA is unaffected.

For most operating RIT is desired and for convenience the RX/TX CHANNEL may be left in the RA/TB or RB/TA position. In addition, by pressing inverting AB, TX offset is possible using main TUNING A/B or TUNING C and pressing SET, thereby returning to split operation from RIT.

MEMORY

Memory data may be entered with TUNING C lever switches. Select 1 through 8 memory. Press SET, display will show new frequency. Press WRITE to enter into memory selected. To store data, switch RX/TX CHANNEL out of that memory position. To recall frequency, select memory and press READ. Frequency is displayed and automatically entered into A VFO.

To retain frequency data in the memory positions the RX/TX CHANNEL switch must not be in one of the memory positions when the main power to the transceiver is turned off.



AUTO-WRITE

To enter or update memory using TUNING A/B knob, select memory 1 through 8. Memory and A VFO is automatically updated as knob is rotated. To store data, switch out of that position.

Auto-write only affects memory channel selected. To retain all 8 memories and disable auto-write, switch to A, RA/TB, B or RB/TA.

INTERFERENCE REJECTION

PASSBAND TUNING

In passband tuning mode, adjusting main TUNING A/B PASSBAND toward left of center shifts the filter passband to a lower frequency. Positioning to right of center shifts passband to a higher frequency.

Figure 4 shows how both the 40.455 MHz 1st IF and 455 KHz 2nd IF passbands are simultaneously tuned away from an interfering signal to put it outside the passband to eliminate interference. Tuning rate is in 10 Hz steps up to ± 5 KHz from the center frequency. Continued passband tuning is automatically limited when the ± 5 KHz point is reached.

Tune in desired signal. Press PBT button, PBT OFFSET indicator will light. Rotate TUNING A/B PASSBAND to desired amount and direction for optimum reception of the wanted signal. The display will show the original receive frequency with the added passband offset. To rezero passband, press RESET.

With a PBT offset, pressing one of the tuning rate buttons, the display will now indicate the original receive frequency with the passband offset added. Receiver can now be tuned while retaining the desired passband offset. Again to recenter the passband, press RESET. Display will instantly change showing a receive frequency LESS the previous offset. PBT OFFSET indicator is now off.

Pressing the inverting AB button, the transmit frequency is displayed and received with no passband offset. If receiving CW signals the passband is more effective when using the higher RX CW OFFSET frequencies.

IF NOTCH

The IF NOTCH control is used to reject unwanted carriers within IF filter passband. Notch frequency range is ± 5 KHz from center of 455 KHz passband.

Pull control forward to enable, rotate knob to adjust frequency of notch for attenuation of unwanted carrier.

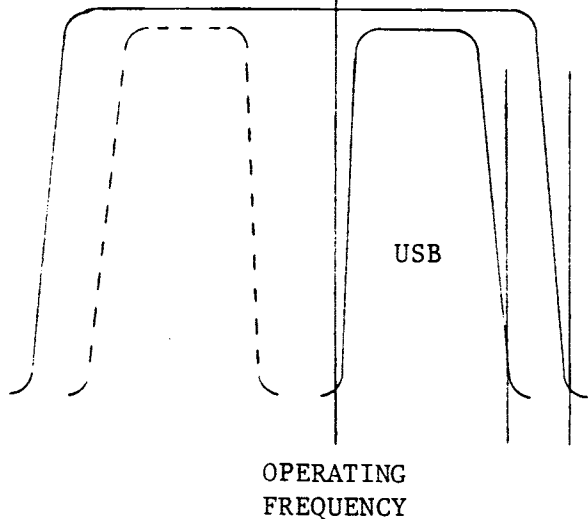
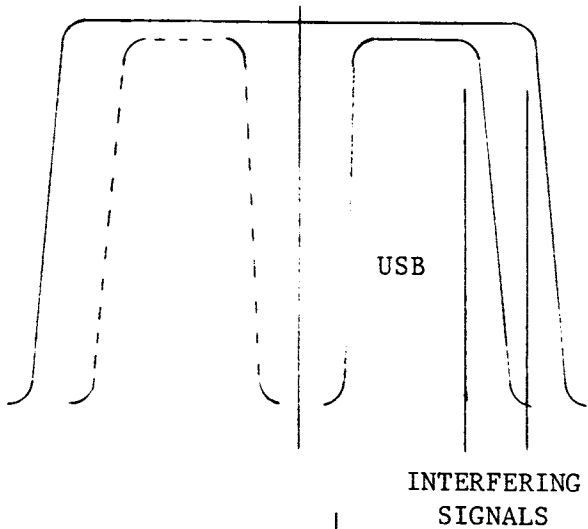
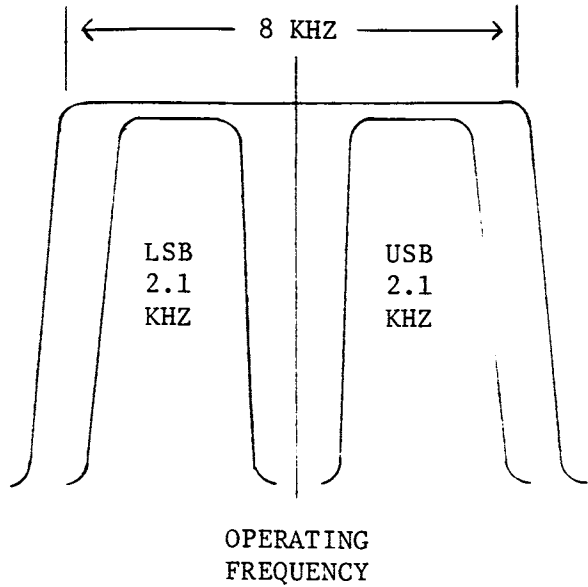

FIGURE 4.

PASSBAND TUNING.

8 KHZ - 40.455 MHZ 1st IF CRYSTAL FILTER.

2.1 KHZ - 455 KHZ 2nd IF MECHANICAL FILTERS.

WITH PASSBAND CENTERED.

INTERFERING SIGNALS SHOWN IN 1st AND 2nd IF PASSBANDS.

IN PASSBAND TUNING MODE.

1st AND 2nd IF FREQUENCIES MOVE TOGETHER IN RELATION TO 1st AND 2nd IF FILTERS.

INTERFERING SIGNALS MOVED OUT OF RESPECTIVE PASSBANDS.



NOISE BLANKER

The NOISE BLANKER sees a "window" of the 8 KHz 1st IF crystal filter and is optimized to reduce longer period type pulses such as over the horizon radar "woodpecker" and fast rise time noise such as automobile ignition and power line noise.

NOISE BLANKER is disabled with control at 0. Turning clockwise adjusts threshold where noise reduction is optimized, usually around 3 to 5 on the scale depending on band conditions.

TX OUTPUT

TX OUTPUT controls RF output level of the final amplifier in TUNE, CW and SSB operation. With matched 50 ohm non-reactive load at antenna jack, advancing TX OUTPUT will cause the amber ALC LED to come on indicating start of automatic limiting action around 30 to 40 watts below maximum output of 150 watts or 200 watts with high power option. Refer to Table 1 for determining actual forward and reverse power readings.

CLIPPING

When transmitting SSB, adjust TX OUTPUT to about 3 to 5. With CLIPPING at 0 no RF clipping is introduced. Advance to about 1 to 2 for minimal or 3 to 5 for moderate clipping. Amber ALC LED indicates the voice peaks, with higher clipping levels indicated with indicator being on more.

Clipping is placed between 40.455 MHz 1st IF crystal filter and 455 KHz 2nd IF mechanical filter to reprocess and eliminate any IMD generated outside the passband of both filters and can be run at a higher level with less intermodulation distortion than the more common audio processing found in other systems.

TX AUDIO

Indicates relative level of microphone audio to input of microphone amplifier. Internally adjust R23 on AUDIO/POWER SUPPLY (A16) board for 2 to 3 meter reading on normal voice peaks. Different microphones give different outputs and R23 should be adjusted to give proper level. A good quality high impedance dynamic microphone will give excellent results with the MILSPEC 1030 transceiver.



VOX GAIN

Adjusts threshold at which transmit occurs on voice levels in VOX mode. Control typically set around 2 to 3.

CW/VOX DELAY

Controls drop out delay between transmit and receive after transmit/AFSK audio input ceases or when operating semi break-in CW while in VOX mode. Adjustable from 10 milliseconds to approximately 1.5 seconds.

ANTI-VOX

Anti-vox control pot R60 on AUDIO/POWER SUPPLY (A16) board controls the amount of negative feedback to inhibit operation of the VOX amplifier circuits to eliminate tripping of VOX with speaker audio. Although adjusted at the factory, it may be readjusted by placing the microphone a few inches from the speaker, then setting R60 so that the speaker audio will not trip the VOX circuitry.

AGC

The automatic gain control, AGC, rate is controlled with the FAST/SLOW AGC button. For SSB reception a SLOW, double hang decay with .5 second hold and .5 second release is normally used. For CW a FAST decay of .1 second may be used. In AM operation the double hang function is disabled with FAST delay of 45 milliseconds. The AGC may be disabled with ON/OFF button and receiver gain manually adjusted with RF GAIN control.

RX CW OFFSET

In CW mode only, a CW signal may be listened to with a frequency other than the usual 800 Hz note. A 0, 200, 300, 400, 600, or 800 Hz audio note may be selected. This automatically offsets the BFO. Display shows true received carrier frequency. Selection of lower notes desired in DX operation to ease detection of wanted signal "in the pile".

CW SIDETONE

Frequency changes with setting of RX CW OFFSET switch and level is adjustable with R16 on AUDIO/POWER SUPPLY (A16) board.



CW OPERATION

For precise tuning in CW insuring true transceive, tune in stations using 0 Hz, RX CW offset. Tune for zero beat.

Select desired RX CW offset for optimum listing tone.

Precision tuning corrections may then be performed using spot button to provide reference tone.

ALTERNATE CW OPERATION

RX CW offset in 800 Hz position. Press PBT push button. Increase frequency readout by 800 Hz. Return to 10 Hz tuning rate for normal CW tuning.

Tuning any station to produce 800 Hz tone (using spot button for reference) will guarantee true transceive and the actual operating frequency will be displayed during transmit or whenever AB swap is depressed.

If an increase in selectivity is desired by going into CW2 narrow mode push reset; this returns the passband and display to normal transceive configuration.



SPOT

Used in conjunction with RX CW OFFSET to provide selected audio notes to aid in placing your transmit frequency in the clear in relation to the "CW pile" in DX operation. Level is adjustable with R15 on AUDIO/POWER SUPPLY (A16) board.

"S" METER

When the PA VOLT and PA CUR buttons are out, meter reads the receive signal level in "S" units. Each "S" unit is approximately 6 dB for levels below "S9". Above that, each increment is 10 dB to the full scale limit of 60 dB. An "S9" reading indicates a 50uV RMS RF level present at the rear panel ANTENNA jack.

Table 3 determines actual forward and reflected power from 0 to 5 scale.

TABLE 3.

<u>METER INDICATION</u>	<u>EQUIVALENT WATTS</u>
0.0	0
0.2	1
0.4	2
0.6	4
0.8	7
1.0	10
1.2	14
1.4	19
1.6	25
1.8	33
2.0	40
2.2	48
2.4	57
2.6	66
2.8	75
3.0	85
3.2	100
3.4	108
3.6	118
3.8	130
4.0	140
4.2	150
4.4	170
4.6	190
4.8	200
5.0	210



MILSPEC 1030C SPECIFICATIONS

GENERAL

FREQUENCY COVERAGE: 10 KHz to 29.99999 MHz receive, 10 KHz to 1.6 MHz at reduced sensitivity. 1.6 to 29.99999 MHz transmit. Resolution of 10 Hz.

FREQUENCY CONTROL: Fully synthesized to 10 Hz resolution; referenced to a single 10 MHz High Stability Oscillator (internal or external via rear panel connector). Tuning A/B - optical shaft encoder tunes frequency in increments of 1 KHz, 100 Hz or 10 Hz selectable with front panel pushbuttons. Tuning C - front panel lever switch for presetting frequencies to within 10 Hz. Frequency entered by SET button, display and selected U/D counter updated. Memory - frequencies stored in any of 8 memories, recalled from Tuning A/B with READ; frequencies from Tuning A/B or C entered into memories with WRITE. Remote computer control via rear panel 60 pin connector and BCD parallel frequency command buss allows a wide variety of optional specialized frequency control schemes. An optional computer interface module is available to provide augmented control of this buss providing full remote control via RS 232 communications.

STABILITY: 1 ppm/month, 1 Hz/C. 1 ppm after 15 minute warm up at 25°C stability is within ± 100 Hz over the temperature range of 0-50°C - typical standard reference oscillator; optional oven controlled reference oscillator is within ± 10 Hz over the temperature range.

FREQUENCY CHANNELS: Virtually an infinite number of channels are accessible using TUNING C leverswitch frequency entry with resolution to 10 Hz. Ten discrete channels can be permanently stored within the memory provided and is switch selected at the front panel.

MODES: AFSK, LSB, USB, CW in transmit; AM, AFSK, LSB, USB, CW in receive.

DISPLAY: 7 Digit, 10 Hz resolution display. Red .43 inch characters, multi-colored display optional.

POWER INTERRUPT, FREQUENCY RETENTION: Data held in memories and U/D counters. Upon restoration of power, transceiver automatically returns to previously tuned frequency.

POWER SUPPLY: Built - in heavy duty AC/DC supply with Hypersil transformer 120/240V AC, $\pm 5\%$, 50 to 400 Hz. 12.6 to 15V DC at 30 amps max., negative ground. 120 watts maximum in receive, 600 watts peak at full transmit power. Thermal and current overload protection.

WEIGHT: 50 pounds.

SIZE: 16.2 inches wide; 7.8 inches high; 17.8 inches deep.

OPERATING TEMPERATURE: 0° to 50°C (32° to 122°F); 0 to 90% relative humidity.



RECEIVE SYSTEM

SENSITIVITY: .25uV (-118 dBm) or better for 10 dB S:N ratio at antenna input 1.6 to 30 MHz (2.1 KHz width in SSB) 2.6uV (-98 dBm) for 10 dB S:N ratio in AM. Matched 50 ohm measurement (12 dB noise figure).

SELECTIVITY: 1st IF, 40.455 MHz \pm 4 KHz @ -6 dB, 1 dB ripple, 8 pole crystal filter; 2nd IF, 455 KHz mechanical filters @ 3 dB:

Standard

USB 2.1 KHz
LSB 2.1 KHz
CW1 1.9 KHz

Optional

CW2 375 Hz
CW2 200 Hz (extra steep skirts)
AFSK/LSB 300 Hz (centered on high tone pair)
AM 5.8 KHz

INTERMODULATION DISTORTION: typical 3rd order input intercept point is +20 dBm for signals separated 20 KHz apart, 2nd order IMD is -80 dB.

CROSS MODULATION: Unmodulated wanted signal of 100uV together with a modulated (30% @ 1KHz) unwanted signal of 100mV spaced 30 KHz apart produces 10% cross modulation. 100KHz separation, -90 dB minimum.

BLOCKING: Attenuation of a wanted AF signal of 1 uV, caused by an unmodulated unwanted signal of -30 dBm spaced 20 KHz apart, produces 3 dB of blocking. 100KHz separation; -100 dB minimum.

IF REJECTION: 80 dB

IMAGE REJECTION: 80 dB

OSCILLATOR RE-RADIATION: 10uV

SYNTHESIZER PHASE NOISE: Mean S/N ratio of 1st. L.O. (typical, reference to 1 Hz bandwidth) 90 dBc, 1KHz from carrier; 135 dBc, 20 KHz from carrier. Equivalent to receiving a 1 uV SSB signal in the presence of a -30 dBm signal (+40 over S9), \pm 20 KHz from the desired signal.

SYNTHESIZED PASSBAND TUNING: 455 KHz (1st. IF) and 40.455 MHz (2nd. IF) tunes in 10 Hz steps over \pm 5 KHz range with respect to 1st. and 2nd. IF filter passbands, controlled by TUNING A/B.



NOISE BLANKER: Dual mode (auto select) pre IF blanker with adjustable threshold and 80 dB dynamic range; effective on pulse noise, i.e. Over the Horizon Radar and ignition type.

IF NOTCH FILTER: 300 Hz @ 6 dB notch in 2nd. IF. Adjustable \pm 1.5 KHz over entire passband with 50 dB rejection. Receiver AGC not affected by notched signal.

AGC RANGE: 120 dB, minimum.

AGC THRESHOLD: .25uV minimum, audio output change is less than 6 dB for 1 uV to 1 V RMS RF input.

AUDIO OUTPUTS: 2 watts nominal into a 4 ohm load @ 1 KHz. Not more than 5% distortion with 1 uV input signal. Not more than 10% distortion with 2 uV input signal. Line Output: +10 dBm maximum, adjustable, 300 ohm unbalanced (standard); 600 ohm balanced (optional).

AUDIO FREQUENCY RESPONSE: Less than 5 dB variation from 300 to 2400 Hz.

RECEIVER PROTECTION: Full front end protection is provided using RF limiting circuitry. Receive signal passes through band pass filters then directly into specially developed high level monolithic double quad balanced mixer, making the system virtually immune to extremely strong local RF energy.

TRANSMIT SYSTEM

POWER OUTPUT: 200 Watt CW/PEP Output; 100% duty cycle; Broadband 1.6 - 30MHz, all modes. Twin PA heatsink cooling blowers, actuate at 130°F. providing automatic fail-safe thermal protection. Power output reduced 10% with 2:1 VSWR. Automatic power output turndown with VSWR greater than 2:1. Nominal 50 ohm output impedance. System consists of Motorola MHW 591 predriver module, MRF 433 drivers, and SRF 3828 finals.

UNWANTED SIGNAL SUPPRESSION: Carrier -75 dB minimum; Undesired sidebands 1KHz, -55 dB minimum; Harmonic (all) - (-40 dB 10 log of mean power output; -63dB reference to 100W PEP). Mixer products, -50dB min.

AUDIO INPUT: Microphone - dynamic, low or high impedance, 3 to 50K nominal impedance. Line input - 40uV RMS for full output.

AUDIO FREQUENCY RESPONSE: 300 to 2400 Hz, not more than 5 dB variation.

THIRD ORDER INTERMODULATION DISTORTION: 30 dB below each of two tones at full PEP output.



LIST OF CIRCUIT BOARDS

<u>BOARD NO.</u>	<u>DESCRIPTION</u>	<u>LOCATION IN UNIT</u>
A1	Reference oscillator, shielded	Chassis top
A2	BFO, shielded	Chassis top
A3	Local oscillator amplifier and 40 MHz oscillator, shielded	Chassis top
A4	Output loop, shielded	Chassis top
A5	Step loop, shielded	Chassis top
A6	1st loop, shielded	Chassis top
A7	Tuning A/B, double boards	Chassis top
A8	Memory	Chassis top
A9	Digital interface	Chassis top
A10	Mother board	Front panel
A11	Readout	Front panel
A12	Push button board	Front panel
A13	Potentiometer board	Front panel
A14	Rotary switch board	Front panel
A15	Receiver, shielded	Chassis bottom
A16	Audio/Power supply	Chassis bottom
A17	Noise blanker, shielded	Chassis bottom
A18	Rear panel board	Rear panel bottom
A19	Pass transistor board	Rear panel top
A20	T/R relay, low pass filter	Chassis top
A21	Driver/Final amplifier	Rear panel top
A22	-15V DC MDA3501 bridge supply	Chassis top left
A23	Fan bracket board, OPTIONAL	Fan bracket
A24	Frequency Comparator	Chassis Top
A25	Low Pass Filter, shielded (OPTIONAL)	Chassis Top

Refer fo Figures 5 and 6 for physical layout of boards in unit.

FIGURE 5.

A21 - Final Amplifier

A20 - Low Pass Filter; T/R Relay

A24 - Freq. Comparator

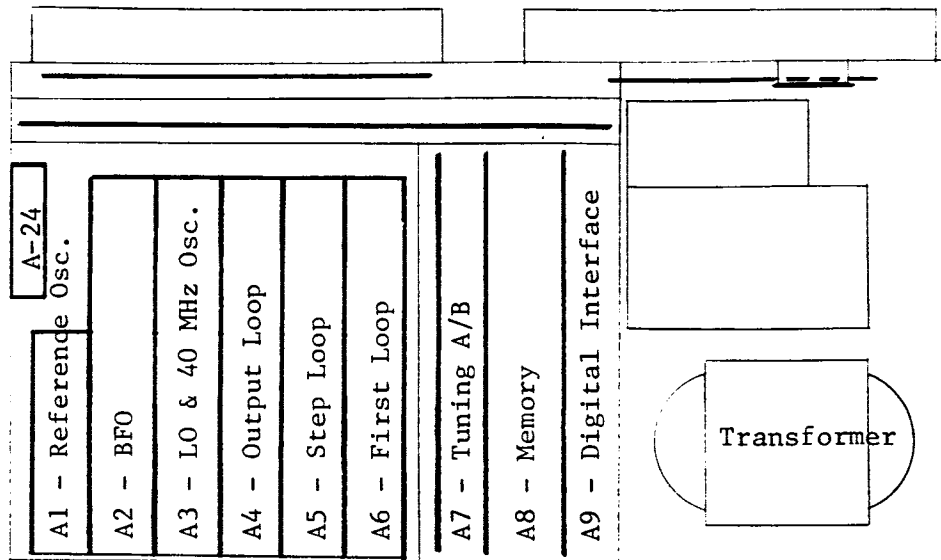

A19 - Pass Transistor

A22 - (-15 DC) Bridge Supply

A10 - Mother Board

A13 - Pot Brd.

A14 - Rotary Switch

A11 - Readout

A12 - Pushbutton

TOP, FRONT

FIGURE 6.

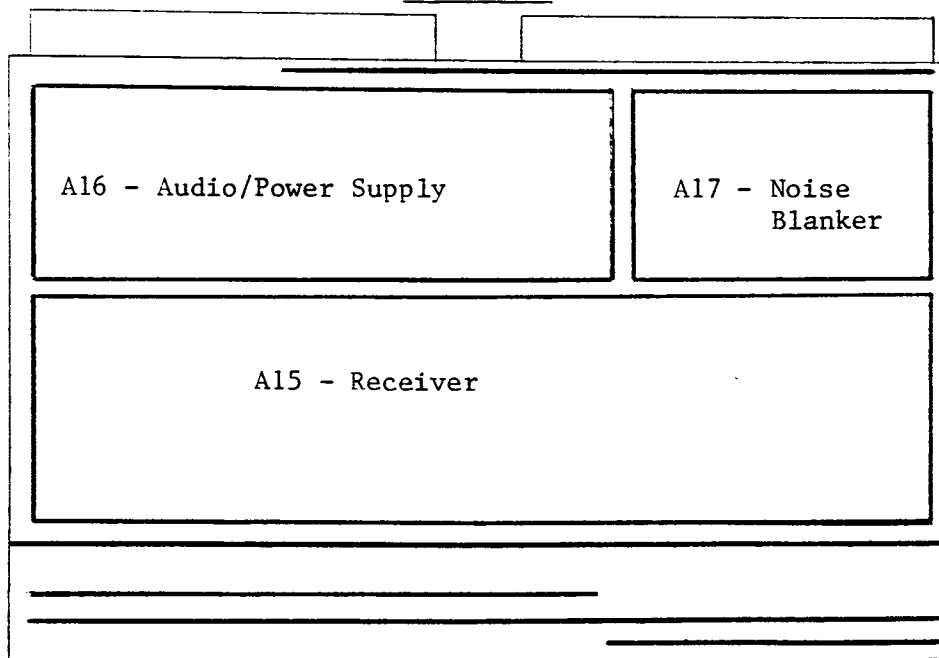

BOTTOM, FRONT

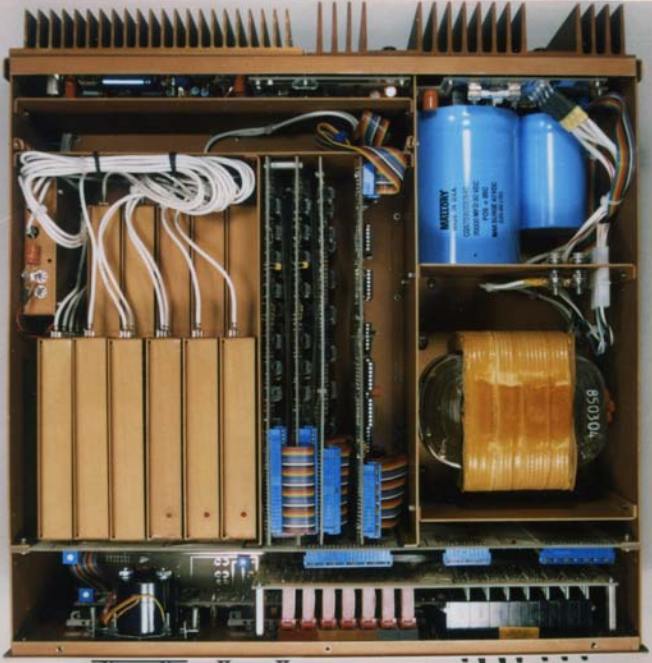

MALLORY

MADE IN U.S.A.
CONSTRUCTION
30000 MFD 50V AC
FOR A BIC
MAY BE USED IN DC
CIRCUITS

850304

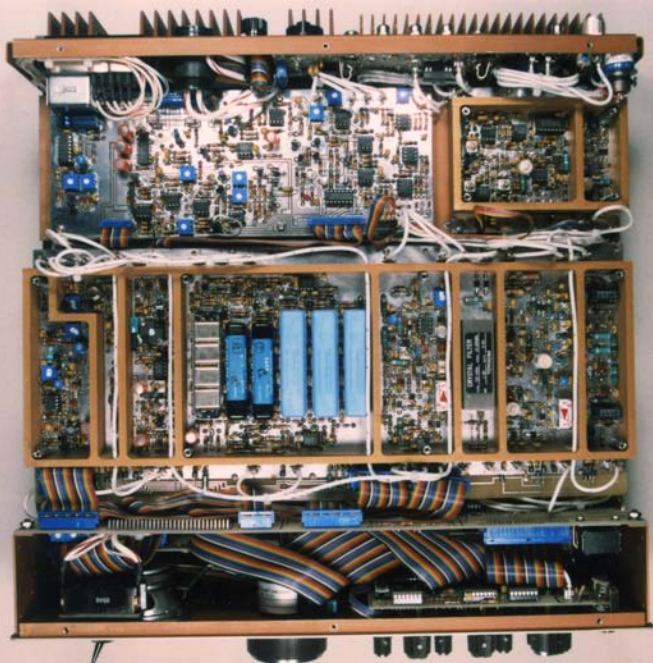



TROUBLESHOOTING

Without specialized test equipment only limited maintenance or adjustments can normally be done. Refer to Table 4 to help determine possible causes of improper operation.

Table 4.

<u>SYMPTOM</u>	<u>POSSIBLE CAUSE</u>	<u>TROUBLESHOOT</u>
Entire unit dead.	Primary power disconnected.	Check AC line or DC source, connectors.
	Fuse in AC connector blown.	Disconnect power, check fuse.
	DC fuse in rear panel holder blown.	Disconnect power, check fuse.
	Rear panel +11 volt regulator defective.	Check for +11V DC at output pin of device.
Rear panel AC or DC fuses blown.	Shorted pass transistors, filter caps, final amplifier transistors.	
Internal high current +12V DC fuse blown, A19 board.	Final amplifier transistors shorted.	Disconnect final amp.
Low or no transmit RF output in tune, +12V red LED on, 0 PA VOLT meter indication.	High current fuse blown.	Disconnect power, check fuse on A19 board.
	TX DRIVE set at 0.	Advance to desired level.
	Thermostat open, shuts of power to pass transistors.	Pass transistor heat-sink excessively warm, +12V red LED on, 0 PA VOLT meter indication.



Table 4, cont.

SYMPTOM

POSSIBLE CAUSE

TROUBLESHOOT

	Final amplifier transistors shorted.	Draws PA CURRENT, no RF output.
	Defective T/R relay.	Disconnect output coax #25 from final amp, set TX DRIVE at 0. Measure resistance between antenna and final amp output cable center conductors. Should read 0 ohms in transmit mode.
	Shorted, open or improper load at antenna jack.	High reflected power indication, amber LED on.
	Synthesizer malfunction.	See synthesizer troubleshooting.
No transmit SSB audio.	No audio input to microphone amplifier.	Check microphone and connector. Check for audio at rear panel TX 600 OHM AUDIO IN jack if using phone patch or AFSK.
		Check TX AUDIO meter indication.
	CLIPPING control at 0.	Set to desired level.
	Mode switch at AM RCV, CW1 or CW2.	Switch to LSB or USB.
No receive signals.	Antenna Disconnected.	
	ANT COM-AUX switch in AUX position and no antenna connected at AUX jack.	
	T/R relay defective.	Bypass T/R relay, connect antenna to AUX jack and switch to AUX.



Table 4, cont.

<u>SYMPTOM</u>	<u>POSSIBLE CAUSE</u>	<u>TROUBLESHOOT</u>
	AF/RF GAIN controls at 0.	Set to desired level.
	Passband tuning not centered.	Press RESET to rezero.
	In transmit mode.	Press PTT/VOX or release microphone PTT switch.
	Synthesizer malfunction.	See synthesizer troubleshooting.
TUNING A/B PASSBAND knob doesn't change frequency display.	All 3 tuning rate buttons out, dial lock condition.	Select desired tuning rate.
	In transmit mode.	Press PTT/VOX or release microphone PTT switch.
Receive signals distorted.	AGC off.	Press AGC button in or reduce gain with RF GAIN control.
	Noise blanker advanced too high.	Reduce control level.
No speaker hiss in receive in USB, LSB CW or AFSK modes.	BFO unlocked.	A2 board defective.
Synthesizer malfunctions.	Internal 1 MHz reference off.	Check for rear panel REF OSC PWR switch at INT. If using external 1 MHz reference, switch must be at EXT and signal applied at EXT 1 MHz REF IN jack.



Table 4, cont.

<u>SYMPTOM</u>	<u>POSSIBLE CAUSE</u>	<u>TROUBLESHOOT</u>
	Output, step and 1st loop locked, NORMAL CONDITION.	Output loop amber LED on, A4 box <u>AND</u> 1st loop red LED off, A6 box.
	Output loop <u>OR</u> step loop unlocked.	Output loop amber LED off, A4 box.
	1st loop <u>ONLY</u> , unlocked.	1st loop red LED on, A6 box <u>AND</u> output loop amber LED off, A4 box.
	40 MHz oscillator unlocked. LO power amp defective.	A3 board defective.



MAINTENANCE

MAIN AC PRIMARY FUSE

10 AMP MDL for 120V AC or 5 AMP MDL for 240V AC operation. Fuse holder is integral part of rear panel AC power connector.

INTERNAL HIGH CURRENT +12V DC

35 AMP 3AGC fuse. Fuse clips are integral part of PASS TRANSISTOR (A19) board. Remove top cabinet half for access.

+12.6 TO 15V DC EXTERNAL SUPPLY

35 AMP 3AGC fuse. Holder located on rear panel.

IMPORTANT: ALWAYS DISCONNECT TRANSCEIVER FROM POWER SOURCE BEFORE CHANGING FUSES. SHOULD A FUSE CONTINUALLY BLOW, REFER TO TROUBLESHOOTING SECTION. BYPASSING OR USING FUSE OF IMPROPER TYPE OR RATING WILL VOID WARRANTY.

CLEANING

Occasional cleaning of exterior of transceiver may be necessary. Clean cabinet and plastic parts with a soft cloth dampened with a mild, diluted liquid soap or detergent. DO NOT use harsh solvents as they may melt plastic knobs or buttons.



SIGNAL ONE PRODUCTS WARRANTY

SIGNAL ONE CORPORATION WARRANTS AS FOLLOWS EACH NEW ELECTRONIC PRODUCT OF ITS MANUFACTURE.

1. Workmanship and all components, EXCEPT FINAL AMPLIFIER RF TRANSISTORS, are guaranteed for 12 MONTHS from date of original purchase if used exclusively in licensed amateur service, and for 18 MONTHS if used in non-amateur service. Government contracts include all parts and labor.
2. Warranty does not apply to repair of damage resulting from improper maintenance for repair, misuse, neglect, abuse, improper installation, overvoltage, lightning, water or wind damage, nor to units not operated in accordance with specifications and instructions furnished by SIGNAL ONE, nor to units repaired or altered by persons not authorized by SIGNAL ONE, nor in cases where the serial number has been removed, altered, or defaced.
3. If a malfunction is suspected, before attempting repairs or returning equipment to SIGNAL ONE for service the owner shall contact selling dealer or factory service department, providing model and serial numbers plus details of equipment hook-up, accessory equipment used, operating conditions and abnormalities observed. SIGNAL ONE will furnish a new part in exchange for any covered defective part or, if it is determined that factory service is required, will authorize return to factory. Equipment authorized for return shall be shipped fully prepaid and insured via United Parcel Service or air freight using only FACTORY APPROVED PACKING; REMOVE POWER TRANSFORMER BEFORE SHIPPING. Return shipping and insurance will be paid by customer.
4. In order to receive warranty service, dealer will return a completed warranty registration form to SIGNAL ONE within 15 days of original purchase. Warranty applies to original purchaser and is not transferable.
5. No person is authorized to assume for SIGNAL ONE any liability, other than as set forth in this warranty, in connection with our products. SIGNAL ONE reserves the right to change its products as it deems desirable, without obligating itself to make such changes available for previously manufactured products.

(UNDER PROVISIONS OF THE FEDERAL MAGNUSON-MOSS WARRANTY ACT, THIS WARRANTY POLICY IS CLASSIFIED AS A LIMITED WARRANTY.)

SIGNAL ONE CORPORATION
1915 W. ADOBE DRIVE
PHOENIX, ARIZONA 85027
PHONE: (602) 581-0056



MILSPEC 1030

OPTIONAL RELAY CONTROL - USED FOR SEPARATE RECEIVE ONLY ANTENNA, CONTEST SPOTTING RECEIVER, OR CONTEST BANDPASS FILTERS

Location: Front Panel, Vox Delay Control - Push/Pull

OPERATING CONDITION SELECTION GUIDE

CONDITION	FRONT PANEL SWITCH	SPARE JACK	RECEIVER AUX ANT	ANTENNA (SO-239)
Transceive	In	NC	NC	Common Tx/Rx Ant
Separate Tx/Rx Antenna	Out	NC	Separate Rx Antenna	Tx Antenna
With Bandpass Filter on Rx	Out	Input of B.P. Filter	Output of B.P. Filter	Common Tx/Rx Ant
With Power Splitter for 2nd Spotting Rx	Out	Input of Power Splitter	Output of Power Filter	Common Tx/Rx Ant

AVAILABLE FROM SIGNAL ONE - SPECIAL CONTEST STATION OPTIONS

Broadband In-Phase 2-Way Power Divider: Allows use of separate spotting receiver for serious contest operation. Available with BNC or Type N connectors. Features Low Insertion Loss (0.5db) Maximum from 2-30Mhz. Phase balance 1.0°. VSWR 1.05:1 Max. Impedance 50 ohms. Signal One Part No. SPL-1 \$ 150.00 - Contact factory direct.

Custom Quarter Octave Bandpass Filters: Special designs optimized for specific Amateur band coverage or Commercial Frequency applications. Attenuates cross-band RF interference from adjacent high power (KW) transmitters. Especially suited for contest stations. Automatically switched by Milspec 1030 via Computer Interface. For information Contact Factory Direct.



MILSPEC 1030

OPTIONAL RELAY CONTROL- CONFIGURATION FOR USING BANDPASS FILTERS

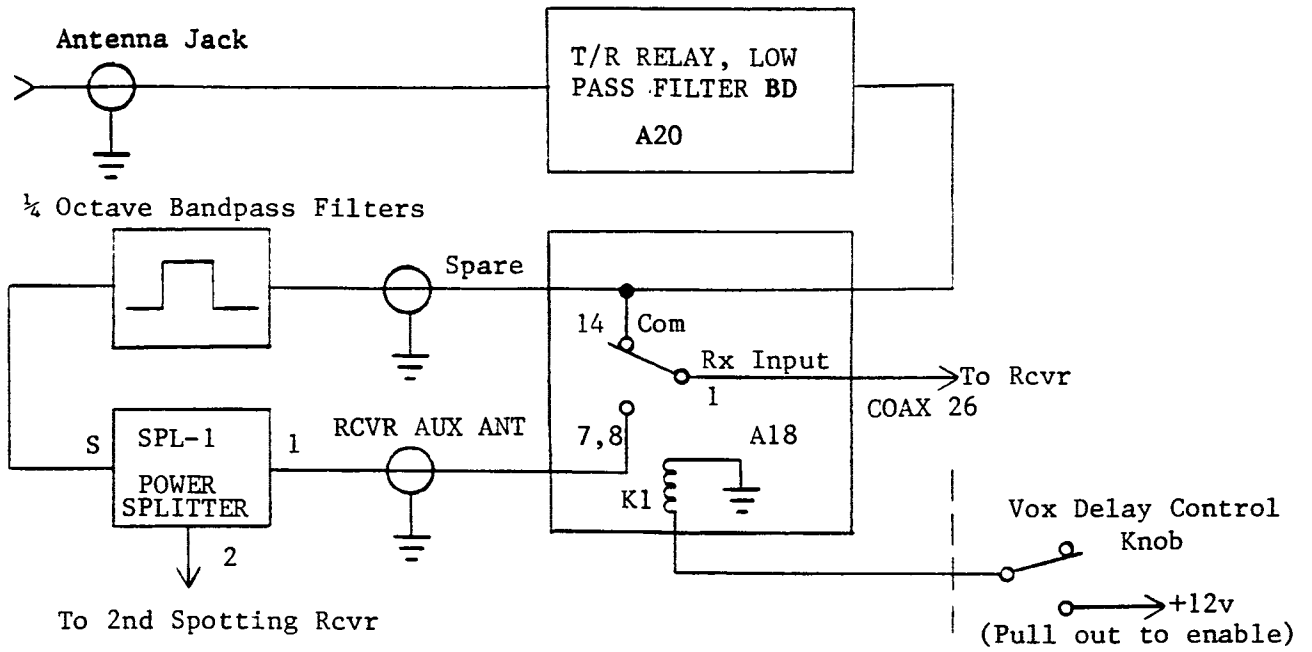

CONFIGURATION FOR USING RECEIVE ONLY ANTENNA & BANDPASS FILTERS

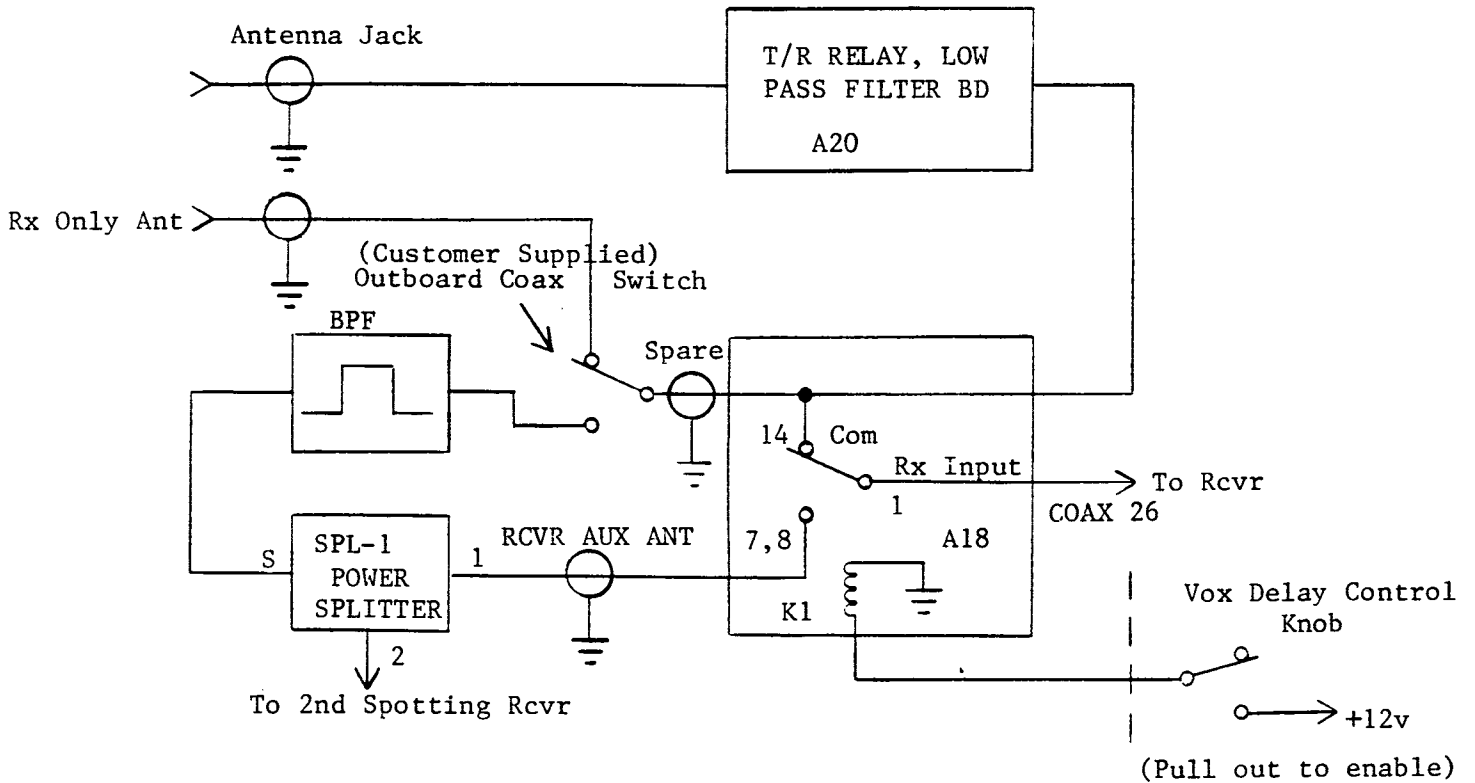



OVERALL ORDER OF TEST

Chassis and Front Panel from final assembly.

1. Check that rear panel AC connector voltage select card is positioned for 120 volts AC.
2. Install 10 amp fuse in AC connector block. Install 35 amp fuses in rear panel DC fuse holder and on A19 PASS TRANSISTOR board.
3. Install power transformer connecting primary wires to connector block and heavy secondary to input of rear panel bridge rectifier, polarity not important here.
4. Check collectors of 2N5685 rear panel pass transistors for shorts to ground. Also check input, output and control lines of rear panel LM396 +11 volt regulator. Check wiring on both filter capacitors for proper polarity.
5. Install A16 board and follow its test procedure to adjust regulators, using Variac to slowly bring up voltage to avoid blowing radio.
6. Select frequency on TUNING C, press SET. Readout should now be TUNING C frequency. Note: Unless A7 A/B boards are installed, some digits may change after SET is pressed.
7. Install A1, A2, A3, A4, A5, A6, A7 A/B, A8, A9 and A20 that have already been pre-aligned and tested.
8. Install A15 and A17. Install A21 that has had bias set. Install fan bracket if high power unit.
9. Complete final alignment and function checks.



A1 REFERENCE OSCILLATOR

FUNCTION 10 MHz internal oscillator divides by 10 to provide 1 MHz reference signal for synthesizers A2, A3, A5 and A6.

ALIGNMENT PROCEDURE

1. Inspect for shorts on board and around coax connectors.
2. Check +11V, +24V, external +11V, frequency calibrate lines and all 5 coax connectors for shorts to ground.
3. Connect extender cables. Connect frequency counter to coax jack normally receiving COAX 19.
4. Apply power. Voltage at L2 should be +24 volts.
5. Check for 1 MHz output on frequency counter, confirm frequency can be varied when R21 on MOTHER BOARD (A10) is rotated.
6. Solder selected NPO capacitor(s) at C10 which allow the 1 MHz reference signal to become "centered" around 1 MHz within the normal min/max ranges of R21. Actual values should be in the 26 to 36pf range. NOTE: The actual range must be centered high to compensate reaching normal operating temp.
7. Check for 1 MHz signal also where COAX 18, 12 and 13 plug in.



A2 BEAT FREQUENCY OSCILLATOR (BFO)

FUNCTION Generates 455 KHz output for BFO and passband tuning function.

ALIGNMENT PROCEDURE

1. Check +11 volt line and coax connectors for shorts to ground.
2. Connect extender cable. Connect 1 MHz reference COAX 18. Connect frequency counter where COAX 22 normally connects.
3. Apply power. VCO voltage should be about 4 volts.
4. Output frequency in USB, LSB or AFSK should be 455 KHz.
5. Output frequency in CW1 or CW2 with the RX CW OFFSET in various positions will be as follows;

0 Hz	455.0 KHz
200 Hz	455.2 KHz
300 Hz	455.3 KHz
400 Hz	455.4 KHz
600 Hz	455.6 KHz
800 Hz	455.8 KHz

Pressing AB swap or TUNE buttons should show same frequency as in receive.

6. Switch to AM, signal should turn off.
7. Switch to USB or LSB. Set readout to 10000.00 KHz. While pressing PBT button, tuning A or B VFO up, readout should stop at 10004.99 KHz and BFO frequency should be 459.999 KHz. Tuning down, readout should stop at 9995.00 KHz and BFO a 450.000 KHz. Pressing RESET should rezero BFO to 455.000 KHz.
8. Check level on spectrum analyzer, should be about -4 to 0 dBm and clean.



A3 40 MHz OSCILLATOR and 1ST L. O. AMPLIFIER

FUNCTION Generates 40 MHz 2nd LO signal, also amplifies 0 dBm 1st LO signal from A4 to +19 dBm.

ALIGNMENT PROCEDURE

40 MHz 2nd LO.

1. Check +11 volt line and coax connectors for shorts to ground. Where COAX 21 connects will read ground.
2. Connect extender cable. Connect 1 MHz reference COAX 19. Connect frequency counter where COAX 21 normally connects.
3. Apply power. VCO voltage (TP1) should be 2 to 10 volts. Frequency should be phased locked and adjustable above and below 40.000 MHz with R21 on MOTHER BOARD (A10).
4. Level on spectrum analyzer should be -3 to 0 dBm and clean.

1st LO AMP.

1. Connect tracking generator with level at 0 dBm to where COAX 16 normally connects. Connect spectrum analyzer to where COAX 17 normally connects.
2. With readout at 00000.00 KHz, output should show a 17 to 19 dB gain with a rolloff starting around 55 MHz. With readout set to 10000.00 KHz, rolloff should start around 65 MHz and with readout set at 20000.00 KHz, rolloff should be around 85 MHz.



A4 OUTPUT LOOP

FUNCTION Combines STEP LOOP (A5) and 1ST LOOP (A6) outputs together to obtain 40 to 69 MHz in 10 Hz steps.

ALIGNMENT PROCEDURE

1. Check +11, +24 lines and coax connectors for shorts to ground. Where COAX 14 and 16 connect will read 0 ohms through U6 and T2.
2. Connect extender cable. Connect COAX 14, 15 and 35. Connect frequency counter to where COAX 16 normally connects.
3. Apply power. Adjust variable transformers L5, L6 and L7 for VCO voltages shown. Check that output frequency remains locked over all ranges and that the amber LED remains on indicating a locked condition.

READOUT	FREQUENCY	VOLTAGE
00xxx.xx - 09xxx.xx	40.455 - 49.455 MHz	3.5 - 12 volts (L5)
10xxx.xx - 19xxx.xx	50.455 - 59.455 MHz	4.5 - 12 volts (L6)
20xxx.xx - 29xxx.xx	60.455 - 69.455 MHz	5.8 - 13.7 volts (L7)

Step through all 1 MHz positions and make sure all ranges remain locked.

4. Check output over all 3 ranges on spectrum analyzer. Level should be +3 to +5 dBm and clean.



A5 STEP LOOP

FUNCTION Provides synthesized output from 40 to 69 MHz in 1 MHz steps.

ALIGNMENT PROCEDURE

1. Check +11, +24 lines and coax connectors for shorts to ground.
2. Connect extender cable. Connect 1 MHz reference COAX 13 and COAX 36. Connect frequency counter where COAX 14 normally connects.
3. Apply power. Adjust variable transformers L5, L6 and L7 for VCO voltages shown. Check that output frequency remains locked over all ranges.

READOUT	FREQUENCY	VOLTAGE
00xxx.xx - 09xxx.xx	40 - 49 MHz	4.0 - 14 volts (L5)
10xxx.xx - 19xxx.xx	50 - 59 MHz	5.0 - 12 volts (L6)
20xxx.xx - 29xxx.xx	60 - 69 MHz	6.0 - 12 volts (L7)

Step through all 1 MHz positions and make sure all ranges remain locked.

4. Check output over all 3 ranges on spectrum analyzer. Level should be +3 to +5 dBm and clean.



A6 FIRST LOOP

FUNCTION Generates 455 to 1.455 KHz in 10 Hz steps.

ALIGNMENT PROCEDURE

1. Check +11, +24 lines and coax connectors for shorts to ground.
2. Connect extender cable. Connect 1 MHz reference COAX 12. Connect frequency counter to where COAX 15 normally connects.
3. Apply power. Adjust by spreading or compressing coils L2, L4 and L6 for VCO voltages shown. Check that output frequency remains locked over all ranges and that the out of lock red LED indicator does not come on.

READOUT	FREQUENCY	VOLTAGE
xx000.00 - xx199.99	455 - 654.99 KHz	2.6 - 9.2 volts (L2)
xx200.00 - xx499.99	655 - 954.99 KHz	2.7 - 9.4 volts (L4)
xx500.00 - xx999.99	955 - 1454.99 KHz	2.6 - 9.7 volts (L6)

4. Check output on spectrum analyzer over all ranges. Check signal at both ends of each range and where the VCO's switch ranges with TUNING A/B.
5. Connect oscilloscope to control voltage line. Set scope to 2V/cm vertical and 10ms/cm horizontal. In RA/TB or RB/TA mode with one VFO at xx000.00 KHz and the other at xx999.99 KHz, the control voltage should settle in 12 to 15 milliseconds while pressing the AB swap button.



A7-A, A7-B TUNING A/B

FUNCTION UP/DOWN counters for A and B VFO's and passband tuning (PBT) function.

TEST PROCEDURE Note: Both boards will be connected to the same cable and tested as one unit. BFO (A2) and DIGITAL INTERFACE (A9) must be installed for proper operation of A7 test.

1. Check board for shorts. Check +11 volt line, Pin 1, and +9 volt battery line, Pin 3. Should read about 3M ohm and infinity, respectively.
2. Connect extender cables. Apply power.
3. Enter 14000.00 KHz into "A" VFO and 24000.00 KHz into "B" VFO. Tune each decade up then down from 0-9-0 in 10 Hz, 100 Hz and 1 KHz tuning rates to include all digits.
4. Select "A" VFO. While pressing PBT, rotate TUNING A/B knob and tune up, frequency should stop +4.99 KHz from starting point. Press RESET, frequency should return to starting point. Repeat while tuning down -5.00 KHz.
5. Repeat above step for "B" VFO.
6. With RX/TX CHANNEL in RA/TB or RB/TA, pressing AB swap button should change display to frequency of appropriate transmit VFO; B or A, respectively.
7. If RX/TX CHANNEL is in A or RA/TB, "B" VFO should synchronize with "A" VFO if SYNC is pressed. If in B or RB/TA, "A" VFO should synchronize with "B" VFO if SYNC is pressed.
8. When all 3 tuning rate buttons are out, neither "A" or "B" VFO frequencies should change when the TUNING A/B knob is rotated.



A8 MEMORY

FUNCTION Provides 8 frequency memories for storing and recalling on "A" VFO.

TEST PROCEDURE

1. Check board for shorts. Check +11 volt line, Pin 38, and +9 volt battery line, Pin 40. Should read about 220K ohm and 3M ohm, respectively.
2. Connect extender cable. Apply power.
3. Switch RX/TX CHANNEL to following positions, load TUNING C frequency, pressing SET, WRITE for each memory position.

MEMORY 1.	10000.00	5.	11111.00
2.	11000.00	6.	11111.10
3.	11100.00	7.	11111.11
4.	11110.00	8.	21111.11

4. Switch RX/TX CHANNEL to each memory position and press READ. Verify that frequency recalled is same as frequency originally stored.
5. WRITE and READ 00000.00, 17777.77 and 29999.99 KHz into all 8 memories. This checks all BCD lines to the board.
6. To check AUTOWRITE function, turning the TUNING A/B knob at least one pulse should automatically write into selected memory whatever is shown on the display.



A9 DIGITAL INTERFACE

FUNCTION 4 functions are contained on this board; interfaces pulses from optical encoder to up/down counters, provides lockout function below 1.6 MHz, selects transmit low pass filters with BCD to Decimal converters and limits tuning range of up/down counters to 29999.99 KHz.

TEST PROCEDURE

1. Check board for shorts. Pin 26 of J1 should read high resistance to ground.
2. Connect extender cable to J1. Apply power.
3. Frequency display should change while turning TUNING A/B knob.
4. Set frequency to 01600.00 KHz. Press 10 Hz. Gate of Q3 should read 0 volts. Tune frequency to 01599.99 KHz. Gate of Q3 should now read +11 volts.
5. Gates of the following FET's should rear +11 volts only within the frequency ranges shown below;

Q7	00000.00 - 01999.99 KHz	Q12	07000.00 - 10999.99 KHz
Q8	02000.00 - 02999.99 KHz	Q13	11000.00 - 13999.99 KHz
Q9	03000.00 - 03999.99 KHz	Q14	14000.00 - 19999.99 KHz
Q10	04000.00 - 04999.99 KHz	Q15	20000.00 - 29999.99 KHz
Q11	05000.00 - 06999.99 KHz		

6. Frequency should not tune any higher than 29999.99 KHz.



A15 RECEIVER

FUNCTION: Detects 10KHz to 30MHz RF receive signal from T/R relay board filters and amplifiers to provide AM,CW,AFSK or SSB audio signals. Also provides low level transmit drive signal.

ALIGNMENT PROCEDURE

1. Check board for shorts. Check +11V line, Pin 4-J1 approx. 220 ohms; T/R line, Pin 12-J1 approx. 22K ohms; R/T line, Pin 14-J1 approx 800 ohms.
2. Connect ribbon cable to J1. Connect COAX 29 to J26; COAX 22 to J24; COAX 11 to J19; COAX 21 to J18; COAX 10 to J17; COAX 27 to J15; COAX 26 to J13; COAX 23 to J3; COAX 17 to J11; COAX 30 to A10 (Mthr. BRD).
3. Connect AC voltmeter to rear panel EXTERNAL SPEAKER jack. Apply power. Note: While aligning receiver, always make sure frequency of signal generator is adjusted for max. peak signal level.
4. Inject AM audio signal to J7 on A16 Brd. Signal should be amplified to the internal speaker or headphones and vary with the AF GAIN control.
5. Product Detector Check: 0 dBm, 455KHz signal to J3,A15. Signal should be amplified to the internal speaker or headphones and vary with the AF GAIN control. Adjust RF GAIN control to maximum. Switch mode to LSB or USB.

3rd IF/DETECTOR ALIGNMENT

(STEP 6 ONLY TO BE USED IF STEP 7 CANNOT BE COMPLETED)

6. With front panel AGC off, inject 455KHz (-10dBm) signal to J23. Adjust L3, L4 for peak audio signal level. With RF signal removed and AF GAIN control at max., noise level should be aprox. -47dBm. Reconnect COAX 7 to J23.

455KHz 2nd IF ALIGNMENT

7. Inject 455KHz, -100dBm signal to J4. Adjust L3 in mechanical filter area and L3,L4 in 2nd. IF strip for peak audio signal level. Sensitivity should be .2uV (-120dBm) or better for 10dB S:N ratio.

Inject -50 dBm signal from tracking generator to J23. Connect spectrum analyzer to J3, set reference level to +20 dBm. Adjust R28 for -80 dBm notch depth and L5 for approximately 25 KHz of bandpass as shown. Rolloff into notch must be within 5 KHz.

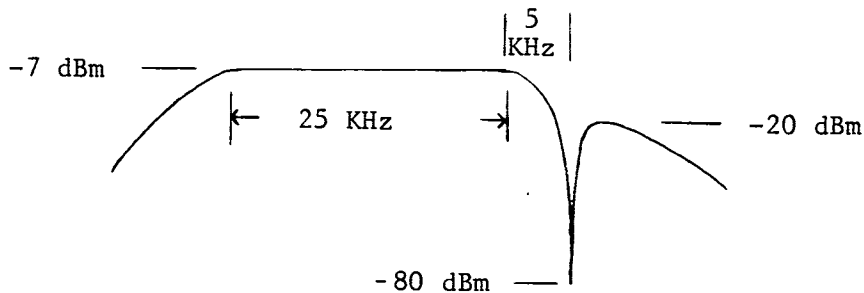

SECOND MIXER ALIGNMENT

8. Note: Heat will affect the setting of this adjustment, perform only after adequate warm - up.
 Remove EMCO CPC-106 mixer U2. Connect spectrum analyzer to mixer sockets as shown below. Level of amplified 40MHz, 2nd. LO signal should be aprox. +16dBm. Adjust L6,R23 for maximum rejection of 80MHz, 2nd. harmonic. Should be at least 50dB below main 40MHz signal. Replace mixer and seal R23 with sealant.

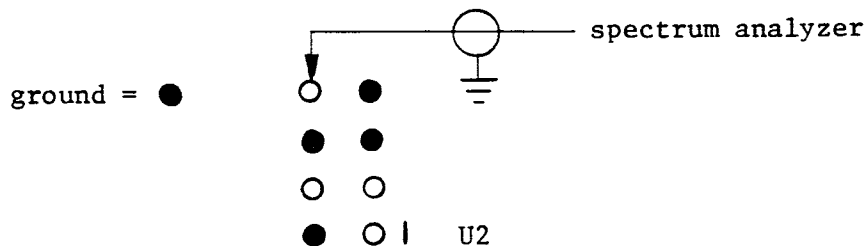

9. Voltage at L5 should be 1.5V in receive. 4.5V in transmit with RF DRIVE at minimum and 2.2V at maximum. Re-install mixer module.
 Monitor TX signal at J9 (40.455) with spectrum analyzer. Press TUNE, vary TX DRIVE control for -10dBm full power to -40dBm no power (TX DRIVE CCW). Select R11 for this range: value must be set so that no compression occurs at either high or low end of pot. Typ. value 39-47K ohm.
10. Inject 40.455MHz (-100dBm) signal to J19. Adjust L2 for peak audio signal level. Sensitivity should be .2uV (-120dBm) or better for 10dB S:N ratio. Connect COAX 11 to J19.

FIRST MIXER ALIGNMENT

11. Remove EMCO CPC-106 mixer (U1). Inject 0dBm signal from tracking generator to mixer sockets as shown. Connect spectrum analyzer to J10. Adjust center screen of analyzer to 40.455MHz with marker from signal generator.

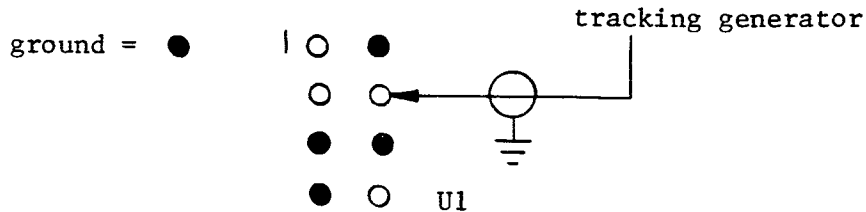

Adjust trimmer capacitors C4 and C12 along with spreading air wound coils L1, 2, 3 and 4 in equal amounts for a peak at 40.455 MHz. Should show gain of 13 to 14 dB. Check bias of Q3 (MRF525) for 70ma as indicated by a voltage at R32 of approx. 9.8 volts. Reconnect COAX 6 to J10. Set spectrum analyzer to 2MHz/div horizontal, 2dB/div vertical and a reference level of +20 dBm when making the above adjustment.

Inject 0dBm signal from tracking generator to J14. Connect spectrum analyzer to mixer sockets as shown below. Adjust L10,11,12 for flat response and rolloff just above 30MHz. Loss through filter should be 1dB or less. Replace mixer and reconnect COAX 1 to J14.

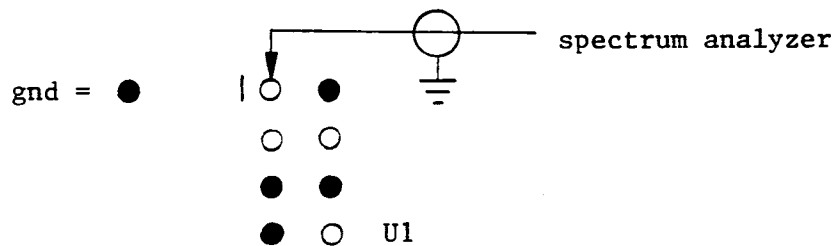

Inject 0 dBm signal from tracking generator to J15. With spectrum analyzer still connected to U1 as above, check for proper response of 0 through 30 MHz transmit drive sloping filter. Should show about 14 dB attenuation at 0 MHz and slope up to no attenuation between 25 to 30 MHz.

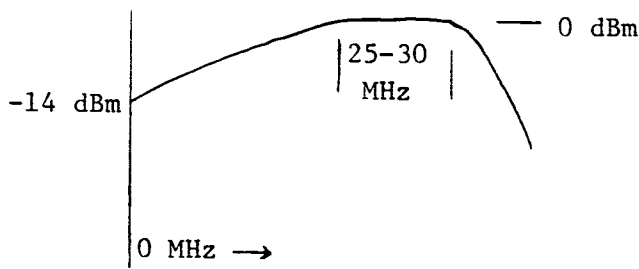



FRONT-END FILTER ALIGNMENT

12. Inject 0dBm signal from tracking generator to J13. Connect spectrum analyzer to J12. Tune display to 01600.00KHz. Adjust L3,L4 for flat response and rolloff just above 30MHz. Loss through filter should be 1dB or less.

Tune display to 01599.99KHz. Filter should show an attenuation of approx. 10dB with the rolloff starting just above 2MHz. No adjustments are necessary. Reconnect COAX 26 to J13, COAX 1 to J12.

Press TUNE, in transmit mode no signal should pass through front end filter.

AUTOMATIC GAIN CONTROL (AGC) ALIGNMENT

13. Inject -30 dBm, 14.3 MHz signal to antenna jack. Connect spectrum analyzer to J3. Adjust R3 so that 2nd harmonic is 42 dB below 455 KHz fundamental. Vary signal level from -30 to -120 dBm, 455 KHz IF signal should not vary more than 6 dB over that range.

Remove signal from antenna jack. Measure voltage on + side of C11 in AGC section. Will be around 2.2 volts. Adjust L3 in 2nd IF section clockwise so voltage on C11 is 1.8 volts.

Connect oscilloscope to last jumper with ferrite bead to left of J1. Set scope for 1V/cm vertical and .5 second/cm sweep. Inject 50mV, 14.3 MHz signal to antenna jack. With AGC switched on, switch signal generator on and off, confirm both FAST and SLOW AGC discharge patterns as shown.

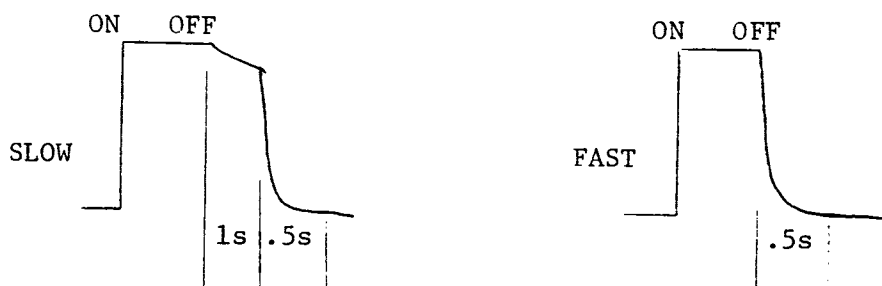

"S" METER CALIBRATE

14. Inject 50uV, 14.3 MHz RF signal to antenna jack. With RF GAIN at maximum, press AGC button to ON. Using clip leads from CR24 and R62 positions on mother board, select 1N5228 zener diode and series resistor, typically 1K ohm, to give around "S7" on meter. Parallel across both diode and series resistor with a 10 to 22K ohm resistor to bring reading up to "S9".

Increase signal level in 10 dB steps, meter should step in 10 dB steps above "S9". Return level to 50uV. Decrease level in 10 dB steps, meter should drop about 2-3 "S" units for each step with a 1uV level reading "S1". Values may be varied to achieve proper meter action.



CARRIER NULL

15. Connect spectrum analyzer to J27. Inject 10mV, 1000 Hz audio signal to front panel MIC jack. Switch mode to USB or LSB and press VOX button. Adjust R11 in product detector section for minimum carrier on the 455 KHz DSB transmit signal. Carrier should be at least 50 dB below the sidebands. Peak sideband levels should be -30 dBm. Seal pot.

IF NOTCH ALIGNMENT

16. Turn radio upside down, facing front. Locate 3 pots at top-left, on front side of mother board (A10). Preset pots to approximate positions shown. Inject -80 dBm, 14.3 MHz signal to antenna jack. Switch mode to LSB. Pull out IF NOTCH control and set to position 8. Rotate TUNING A/B for low frequency beat note on signal. Adjust L5 in 3rd IF section for null on "S" meter. Adjust R28 for maximum null. Rotate TUNING A/B for high beat note. Adjust IF NOTCH control to reject high note, should occur around position 2. Adjust L5 to give equal control rotation from low to high note rejection.

Switch mode to USB. Rotate IF NOTCH control to position 2. Rotate TUNING A/B for low beat note. Adjust R56 for signal rejection. Rotate TUNING A/B for high beat note. Rotate IF NOTCH to reject high note, should occur around position 8. Adjust R56 to give equal control rotation from low to high note rejection.

Switch mode to CW1, using USB procedure adjust R61 to align notch for CW mode. Total rotation of IF NOTCH control in CW1 mode will be less than in SSB due to narrower bandwidth.

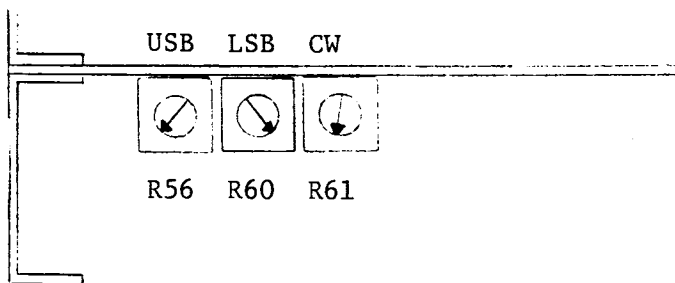

TRANSMIT DRIVE CHECK

17. Connect spectrum analyzer to J15. Press TUNE. Rotate TX DRIVE control from minimum to maximum. Level of drive signal should range from -50 to -10 dBm and be free of spurs and harmonics.



A16 AUDIO/POWER SUPPLY

FUNCTION Provides regulator functions for the +13.6 and +11 volt supplies. Also provides various receive and transmit audio functions.

ALIGNMENT PROCEDURE Note: Steps 1 through 7 are done when initially powering up radio. Steps 8 through 9 can only be done after receiver is installed and aligned.

1. Check +11 volt, R/T and T/R lines for shorts to ground. Connect ribbon cable to J3. Install board in radio. Connect COAX 30, 29, 33 and 31 to J7, 6, 5 and 4, respectively.
2. Connect AC plug to Variac. Switch radio power switch to ON position. Slowly bring up the 120 AC voltage while monitoring for excessive current draw. If OK, adjust R89 for 13.6 volts at the input of the rear panel LM396 regulator. Adjust R78 for +11 volts at output of LM396. Connect ribbon cables to J1 and J2. Plug radio into 120V AC line current.
3. Check R/T line for 0 volts in receive and +11 volts in transmit. Check T/R line for 0 volts in transmit and +11 volts in receive. Check lines with oscilloscope for fast rise and fall transition times. Amber LED will be on in receive and Red LED on in transmit.
4. Press SPOT button. Adjust R15 for desired spot tone level. Rotate RX CW OFFSET switch. Spot tone frequency should change to those shown on front panel.
5. Switch mode to CW1 or CW2. Ground KEY, PTT line of press TUNE. Adjust R16 for desired sidetone level. Sidetone frequency should change as in step 4 in both CW1 and CW2.
6. Press VOX button and set VOX GAIN control to position 3. Inject 10 mV, 1000 Hz audio signal to front panel MIC jack. Adjust R23 so that VOX triggers at 10 mV input.
7. Inject same audio signal as above to rear panel TX 600 OHM input. VOX should trigger at 10 mV.
8. Hold microphone near speaker. While receiving SSB signals, turn up AF GAIN control until VOX trips. Adjust R60 so VOX drops out.
9. Adjust R63 for maximum audio output at rear panel RX 600 OHM audio output jack while receiving a CW carrier. Level should be about 1 volt P-P.



A17 NOISE BLANKER

FUNCTION Detects narrow line or ignition type noise and wide "Russian Woodpecker" type noise and blanks the receiver for the duration of the pulse.

ALIGNMENT PROCEDURE

1. Check board, J1 and J3 for shorts to ground. J2 will show 0 ohms thru T2.
2. Connect ribbon cable to J3. Inject -20 dbm signal from tracking generator to J1. Connect spectrum analyzer to J2. Calibrate analyzer for a center frequency of 40.455 mhz with marker from signal generator.
3. Apply power. Adjust trimmer capacitor C2 for maximum gain at 40.455 mhz. Amplifier must show a gain of 9 to 10 db. Note, L5 inductor can be replaced to insure amplifier peak at desired frequency.

THE FOLLOWING TESTS TO BE PREFORMED AFTER RCVR BD. IS CALIBRATED AND S METER IS WORKING.

4. Connect COAX 10 to J1 and COAX 11 to J2. Inject -90 dbm, 14.3 mhz signal, am modulated 50% at 400 hz to J13 on A15 RCVR board. Tune in signal on receiver.
5. With oscilloscope on Pin 1 of U3, adjust L2, L3 and L6 for maximum peak to peak signal. The coils may exhibit 2 peaks, adjust for most stable peak.
6. Increase level of signal generator up to -10 dbm. AGC should cause level at pin 1 of U3 to remain fairly constant with only a small amount of distortion.
7. Inject pulse type noise to J13 of A15 receiver board. Adjust front panel noise blanker control for maximum rejection of noise as indicated on the "S" meter. Readjust L2, L3 and L6 for maximum further reduction in noise. Only a small adjustment should be necessary.
8. Vary pulse repetition rate from 2 to 20 ms., receiver noise should be completely gone.
9. *Note full blanking should occur at position 5, S meter should read $1\frac{1}{2}$ S units.
position 6, S meter should read 1 S unit.
position 7, S meter should read 0 S units.
position 8, S meter should read 0 S units.
position 9, noise completely gone.



A20 LOW PASS FILTER, T/R RELAY

FUNCTION Provides low pass filtering and transmit/receive switching functions for final amplifier.

TEST PROCEDURE

1. Check board for shorts. Connect coax jumper from J2 to J8. Connect ribbon cable from J6 of A20 to J2 of A9.
2. Inject 0 dBm signal from tracking generator to J5. Connect spectrum analyzer to J1.
3. Apply power. Check low pass filter rolloff characteristics on each of the following ranges. Watch for proper wiping action on relays K1 through K12 while tuning back and forth across ranges.

00000.00 - 01999.99 KHz	Roll off just above 2 MHz.
02000.00 - 03999.99 KHz	Roll off just above 4 MHz.
04000.00 - 10999.99 KHz	Roll off just above 12 MHz.
11000.00 - 19999.99 KHz	Roll off just above 20 MHz.
20000.00 - 29999.99 MHz	Roll off just above 30 MHz.

Make sure that all relay contacts are clean before installing relay covers.

4. Tune radio to 14300.00 KHz. Connect 50 ohm dummy lead through Bird 43 wattmeter to rear panel ANTENNA jack. Adjust R104 on A16 board for full CW rotation. Set meter for REV function. Press TUNE, increase TX DRIVE for 200 watts output. Adjust C54 on A20 for null in reflected power. Set meter for FWD function. Adjust C51 for 4.8 reading on top scale of meter.
5. Rotate TX DRIVE fully CW. Adjust R104 on A16 so output power is cut back to 200 or 150 watts depending on whether radio is high or low power model.



A21 DRIVER/FINAL AMPLIFIER

FUNCTION Amplifies 0 dBm transmit drive signal from receiver board to 200 watts output.

ALIGNMENT PROCEDURE Note: MRF 421 final amplifier transistors are VERY expensive. Never power up board until you are certain everything is in order.

1. Inspect top of board carefully. Check resistance at high current +13.8 volt, J6 and R/T switching line, J5 to ground. Should be about 500 - 700 ohms and high resistance, respectively.
2. Turn R1 fully CCW. Turn R11 fully CW.
3. Connect a +13.6 volt regulated supply capable of 2 amps output to J6 through a milliamp meter. Without voltage on the R/T (J5) switching line the current should read about 20 ma. If OK, jumper J5 bias switching line to +13.6 volts. Current draw should be about 350 ma.
4. Adjust R1 for 250 ma DRIVER bias over step 3. Total current should be 600 ma.
5. Adjust R11 for 900 ma FINAL bias over step 4. Total current should be 1500 ma.
6. Remove +13.6 voltage from J5. Idleing current should be about 200 ma. Voltage on bases of driver and final transistors should less than or equal to .5 volts.
7. Seal R1 and R11.



A24 SYNTHESIZER LOCK BOX

FUNCTION Combines signals from A4 and A5 to provide a compensation voltage to keep synthesizers locked on frequency.

ALIGNMENT PROCEDURE

1. Check board, +11 volt line and coax connectors for shorts.
2. Connect +11 volts to 10 ohm resistor at feedthru capacitor on box.
3. Connect oscilloscope to output feedthru. Set scope at 2 volts/cm vertical division.
4. Using a BNC "T" connector, inject a 55 MHz, 0 dBm signal from generator to both coax connectors.
5. Adjust trimpot R15 so that output voltage fluctuates between 0 and about +4 volts.
6. Pull coax from J1, at rear of box. Voltage should go high to +11 volts. Replace coax.
7. Pull coax from J2, near feedthru. Voltage should go to 0 volts. With both coax off voltage is about 4 volts.
8. Seal trimpot.



FINAL ALIGNMENT AND FUNCTIONAL CHECKS

NOTE: All transmit checks are performed with 50 ohm dummy load capable of at least 300 watts continuous power dissipation connected to the rear panel antenna jack through a BIRD 43 wattmeter and RF probe (30 dB attenuation RF sniffer) in the coax line. All checks apply to both 150 and 200 watt output models, the only difference being output level. If unit is high power, make sure rear fans come on when heatsinks reach 125° F to provide proper cooling.

TRANSMIT SIGNAL SPECTRAL PURITY

1. Connect RF probe to spectrum analyzer. Set span to 10 MHz/div to observe for spurious signals and harmonics. Select transmit frequency, switch to USB. Press TUNE, advance TX DRIVE to maximum. Any products must be at least 60 dB below main signal. Repeat with several frequencies within each filter range.

CLIPPING ADJUST

2. Plug microphone into MIC jack. With TX DRIVE at maximum and CLIPPING at minimum, adjust R9 on pot board (A13) behind front panel for approx. 25 watts output on wattmeter while whistling into microphone. Advancing clipping control while talking should increase power output.

+12 VOLT RED LED INDICATOR

3. Set frequency to 29 MHz. While talking under full power output, adjust R21 on push button board (A12) so front panel +12 V red LED does not come on with voice peaks. Adjust pot about 1/8 turn beyond that setting.

TWO TONE IMD

4. Set spectrum analyzer to 1 KHz/div. Inject 400 and 1400 Hz audio signal, each with 20mV RMS level into MIC jack. With TX DRIVE at maximum, press XMIT. Advance CLIPPING for 50 watts output. Both audio product signals should be the same level with third order IMD products down at least 25 dB. Switch to LSB, levels should remain the same with little change in total power output.

TRANSMIT MIC AUDIO RESPONSE

5. Inject 20mV RMS, 400 to 2400 Hz audio signal to MIC jack. Press XMIT, with TX DRIVE at maximum, advance CLIPPING for 50 watts output. Vary frequency, output power should remain constant over above range.



ALC SHUTDOWN

6. In USB, LSB or AFSK pressing XMIT, or in CW1 or CW2 pressing TUNE should not produce any power output when advancing TX DRIVE. There is no output in AM when pressing TUNE or XMIT.

Connecting two 50 ohm dummy loads in parallel, 2:1 VSWR, should reduce power output by 10% under full power output. With a 3:1 VSWR, power should be reduced to 100 watts or less.

Connect minus lead of variable power supply to external ALC input on rear panel. Connect plus lead to chassis ground. With full power output in TUNE, advance voltage until output power is totally cutback to zero. This should occur with approximately -6 volts at external ALC.

CW KEYING

7. Connect RF probe to oscilloscope, connect PTT line of radio to external trigger input of scope. Connect electronic keyer to rear panel KEY jack. Set mode to CW and PTT, key radio for continuous dots or dashes and advance TX DRIVE. Set scope for 10ms/div sweep and adjust to trigger on PTT keying signal. There will be a 10ms delay before actual start of RF envelope. Check for proper rise and fall. Check keying in full break-in QSK (PTT) and semi break-in (VOX) and at various speeds.

TX 600 OHM AUDIO IN

8. Inject 10mV RMS, 1000 Hz audio signal to rear panel TX 600 OHM input. With mode in USB, set VOX GAIN to 3, press VOX. Unit should trigger in VOX mode. Increase TX DRIVE and CLIPPING to confirm power out.

LINEAR CONTROL

9. Connect ohmmeter to rear panel LINEAR CONTROL jack to ground. In receive, should be high impedance, in transmit 22 ohms.

RX 600 OHM RX OUT

10. Inject 50mV, 14.3 MHz signal to antenna jack. Connect oscilloscope to rear panel RX 600 OHM output. Tune in signal for maximum reading. Adjust R63 on audio/power supply (A16) for maximum level, about 1 volt P-P.



SYNTHESIZER PHASE NOISE

11. Inject -30 dBm, 14.3 MHz signal to antenna jack. Tune \pm 20 KHz of signal, "S" meter should read less than "S1".

RECEIVE AUDIO

12. Plug headphones onto PHONE jack. With RF GAIN at minimum and AF GAIN at maximum, there should be no discernable 60 Hz hum. Connect antenna to antenna jack. Tune in clean, solid SSB signal, make sure there is no audio distortion.

FREQUENCY CALIBRATE

13. Tune in WWV or other frequency standard. Switch between USB and LSB. Adjust R21 on mother board (A10) for zero beat or equal audio pitch.

OPTIONAL I.F. FILTERS

14. Check all mode positions for proper reception. If a position doesn't have a filter, temporarily plug one in for test. If using a crystal filter in CW2 position, clip ground side of C12 and C15 in FL6 position and lift in air.

AM AGC

15. Switch to AM. Tune in strong AM broadcast station. Adjust R13 for minimum distortion.



CIRCUIT DESIGN

The Milspec 1030C is a double-conversion superhetrodyne receiver and single sideband transmitter employing fast switching synthesizers using extensive CMOS circuitry. The transmitter operates on either sideband for voice transmission. CW transmission is generated by keying a carrier oscillator. For RTTY transmission an external AFSK modem is required to generate audio signals for modulation on USB/LSB. The receiver has a product detector for SSB and an envelope detector for AM reception. Figure 2 is a simplified block diagram of the transceiver. Voice/teletype crypto compatible, field selective, IF bandwidth filters supplied.

RF frequencies for all the receiver-exciter circuits are fully synthesized. The 1st L.O. frequencies are synthesized by a 3 loop phase locked synthesizer (A3, A4, A5, A6 and A24) that is tunable in 10Hz steps. A second single loop phase lock oscillator is provided for the 40MHz 2nd L.O. frequency. A third single loop phase lock synthesizer is provided for the 455 KHz 3rd L.O. (BFO) frequency. A separate 10 MHz crystal oscillator (A1) generates the 1 MHz reference frequency for the 1st and 3rd L.O. synthesizers and 40 MHz 2nd L.O. oscillator.

Inputs from the front panel frequency selection controls are applied to the central processing unit (A7, A/B). Up-down counters generate the BCD 1-2-4-8 parallel command to supply frequency data to the synthesizers (A1-A6), control signals to the digital interface (A9), low pass filter assembly (A20), front panel frequency display readout (A11), and full remote computer control data to the internal RS232 computer interface (MSA 26CI). See section Computer Interface.

Receiver selectivity is obtained by low and high pass filters which are selected by the synthesizer control circuits and switched by special relays. After input filtering, the signal is fed via a 30 MHz low pass filter to the first mixer for up-conversion to 40.455 MHz. The first mixer is a very high level double balanced, dual quad push pull design with +22 dBm I_p^3 performance. The L.O. is supplied by the synthesizer operating in the frequency range of 40.465 to 70.45499 MHz in 10 Hz steps. Frequency selection may be made via a three speed (1800 Hz, 18 KHz or 180 KHz per revolution) opto-electrical shaft encoder, lever control thumbwheel switches or remote BCD CMOS parallel commands.

The first mixer is followed by a low noise high intercept amplifier employing narrow band 40.455 MHz circuitry which provides excellent matching for optimum intermodulation performance over a wide frequency range and an 8 pole 40.455 MHz crystal filter within a ± 3.5 KHz bandwidth. Following the filter is a grounded gate field effect transistor amplifier incorporated with the noise blanker diode gating circuitry. The noise blanker is connected into the receiver circuit just before the second mixer, a dual mode blanker which



automatically adapts to one of the two major categories of pulse interference such as over the horizon radar (so called woodpecker) and impulse noise such as ignition and line hash type noise. The overall gain between the first and second mixer is minimized for optimum in band intermodulation performance.

The above signal is then followed by a PIN diode attenuator with 40 dB dynamic range and low noise grounded gate field effect transistor amplifier. This signal drives a second high level mixer identical to the first. The 2nd L.O. is derived from a 40 MHz phase locked crystal oscillator. The 2nd mixer output is fed to a low noise bipolar amplifier and then through a diode matrix switch to provide selection of the desired IF filter. Modern improved mechanical filters are used to minimize intermodulation products and to provide high ultimate rejection. Passband ripple is 1 dB typical. These filters exhibit constant group delay characteristics for excellent SSB and pulse response.

The IF signal is further amplified by two monolithic amplifiers with a total 120 dB AGC range. Between these amplifiers is a notch filter which provides a 60 dB notch, an excellent means of further reducing specific interference without "pumping up" the receivers AGC and resulting loss of receiver sensitivity.

The IF chain terminates into one of two different detectors. An active double balanced product detector processes the SSB and CW signals to achieve very low audio distortion. The AM detector uses envelope detection providing less than 1% distortion.

The AGC voltage is RF derived with separate time constants for SSB/CW and AM. A front panel control is provided to adjust the AGC FAST/SLOW hold time in SSB and CW modes. The receiver characteristics are therefore optimized for the intended mode of operation.

To increase the receivers performance and to minimize interference, IF SHIFT/PASSBAND TUNING is provided. In the PBT mode, the tuning knob is electronically switched to control both the first L.O. synthesizer and the BFO synthesizer. In this mode the tuning knob varies both the L.O. and BFO in synchronization. By this method the IF passband may be shifted up to ± 5 KHz in precise 10 HZ steps. In this manner the passband may be centered on a desired signal or may be shifted to eliminate an interfering signal near one edge of the desired passband.

Two audio channels are provided, a 600 ohm balanced/300 ohm unbalanced output set to 0/-3 dBm but adjustable over a range of -10 to +3 dBm and a 4 ohm, 2 watt output to drive an external speaker.



In transmit, two audio inputs are provided: the high impedance mic input on front panel and 600 ohm input on rear panel for phone patch and AFSK computer modem. The TX audio signal is then amplified and fed into an active double balanced modulator. The resulting DSB signal is fed to an RF clipping speech processor which is implemented by over driving a limiting amplifier in the TX IF chain. The system gains are set to insure that the amplifier is operating just prior to the limiting point with the clipping control at the minimum position.

Increasing the clipping control setting increases the gain of the clipping amplifier thereby enhancing low level audio components without exceeding the peak power as determined by the fixed limiting characteristics of the amplifier.

The resulting out of band distortion products created in this process are removed by a subsequent bandpass mechanical filter which maintains the authorized transmission bandwidth.

Separate LSB and USB filters are provided after processing the USB signal then the appropriate IF filter, the resulting single sideband signal is fed in a reverse direction through the receiver / exciter RF circuitry previously described. The transmit output is applied to the power amplifier. The pre-driver, driver and final amplifier assembly is a broadband type that does not require tuning. The amplifier output is routed through a T/R relay and on to the low pass filter assembly. (In receive, the T/R relay directs the receive signals to the receiver circuits).

A control signal from the digital interface automatically selects the appropriate low pass filters for the frequency of transmission. If the receive frequency is in a different band from the transmit frequency, the CPU automatically switches the designated filter in and out of the RF path as the transceiver is switched from receive to transmit and back. A directional coupler measures the forward and reflected RF power signal. The resulting ALC voltages are coupled back to control the 40MHz pin attenuator. This ALC signal controls the gain to prevent over driving the power amplifier. An ALC signal from an external linear power amplifier may also be applied to the transceiver power amplifier for ALC control of the exciter.

All power for the circuits is developed from the power supply. This supply operates from 115/230 volts (nominal), 50 to 60Hz or 12 to 15V DC for standby or emergency operation. A thermal switch located on the power amplifier heatsink turns off the power supply output if heat from the series - pass power transistors or power amplifier output transistors becomes excessive.



GENERAL

The Milspec 1030 transceiver is sophisticated, versatile and high quality with unequaled performance for communication and surveillance usage in the VLF/LF/MF/HF frequency range.

Special attention has been paid to EMI in the design to minimize both radiation and susceptibility. Mechanical construction features rugged individual shielded synthesizer modules, shielded 8 compartment milled receiver assembly, plug-in ribbon cable and mother board. These features plus sophisticated circuit design assures the ultimate in performance and reliability.

CONSTRUCTION

The Milspec 1030 is designed to provide exceptional RF shielding and rugged mechanical construction to withstand any environment. Critical RF circuits are separated by function and housed in milled aluminum plug-in modules. DC and control lines in and out of each module are individually filtered and all signals are carried on coax cable with miniature connectors. Such construction provides excellent immunity from external RF fields and reduces dramatically internally generated spurious responses and unwanted radiation. All circuit boards are of double sided, plated through glass epoxy material.